

TECHNICAL MANUAL

OPERATORS, ORGANIZATIONAL, AND DIRECT SUPPORT
MAINTENANCE MANUAL AND REPAIR PARTS AND
SPECIAL TOOLS LIST

This copy is a reprint which includes
current pages from changes 1
through 5.

CLOSED CIRCUIT REFUELING NOZZLE

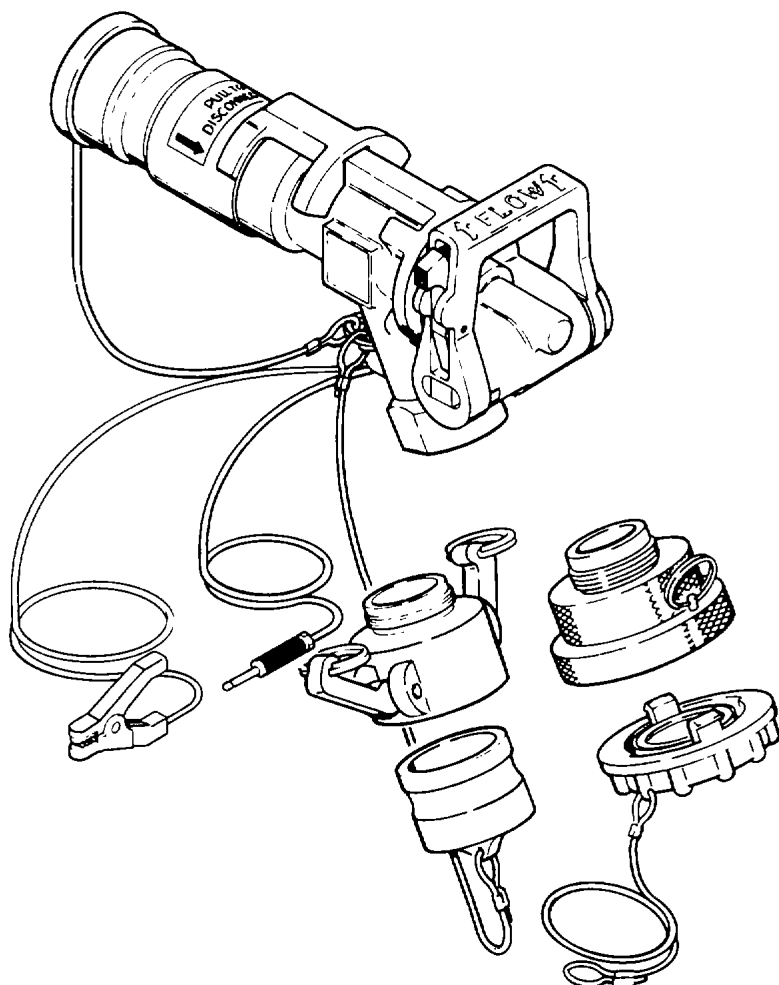

INTRODUCTION

OPERATING INSTRUCTIONS

OPERATOR MAINTENANCE
INSTRUCTIONS

ORGANIZATIONAL MAINTENANCE
INSTRUCTIONS

DIRECT SUPPORT MAINTENANCE
INSTRUCTIONS

REFERENCES

MAINTENANCE ALLOCATION
CHART

COMPONENT OF END ITEM/BASIC
ISSUE ITEMS

ADDITIONAL AUTHORIZATION
LIST

EXPENDABLE/DURABLE
SUPPLIES AND MATERIALS LIST

REPAIR PARTS AND SPECIAL
TOOLS LIST

INDEX

MODEL NUMBERS

NSN 4930-01-194-2625 (AE83206R)

NSN 4930-01-214-2909 (AE83501R)

CHANGE

NO. 6

HEADQUARTERS
DEPARTMENT OF THE ARMY
WASHINGTON, D.C., 24 May 1996

**Operator's, Organizational and Direct Support Maintenance Manual and
Repair Parts and Special Tools List**

**CLOSED CIRCUIT REFUELING NOZZLE
MODEL NUMBERS
NSN 4930-01-194-2625 (AE83206R)
NSN 4930-01-214-2909 (AE83501R)**

DISTRIBUTION STATEMENT A: Approved for public release; distribution is unlimited

TM 5-4930-234-13&P, 24 November 1986, is changed as follows:

1. Remove and insert pages as indicated below. New or changed text material is indicated by a vertical bar in the margin. An illustration change is indicated by a miniature pointing hand.

Remove pages	Insert pages
a/(b blank)	a/(b blank)
i and ii	i and ii
1-1 and 1-2	1-1 and 1-2
2-5 and 2-6	2-5 and 2-6
F-11 and F-12	F-11 and F-12
F-21 through F-26	F-21 through F-26

2. Retain this sheet in front of manual for reference purposes.

By Order of the Secretary of the Army:

Official:

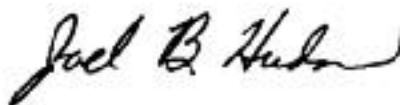

JOEL B. HUDSON
*Administrative Assistant to the
Secretary of the Army*
02009

DENNIS J. REIMER
*General, United States Army
Chief of Staff*

DISTRIBUTION:

To be distributed in accordance with DA Form 12-25-E, block no. 2482, requirements for TM 5-4930-234-13&P.

URGENT

TM 5-4930-234-13&P
C5

CHANGE

NO. 5

HEADQUARTERS
DEPARTMENT OF THE ARMY
WASHINGTON, D.C., 15 July 1995

**OPERATORS, ORGANIZATIONAL, AND
DIRECT SUPPORT MAINTENANCE MANUAL AND
REPAIR PARTS AND SPECIAL TOOLS LIST**

**CLOSED CIRCUIT REFUELING NOZZLE
MODEL NUMBERS**

NSN 4930-01-194-2625 (AE83206R)

NSN 4930-01-214-2909 (AE83501R)

DISTRIBUTION STATEMENT A: Approved for public release; distribution is unlimited.

TM 5-4930-234-13&P, 24 November 1986, is changed as follows:

1. Remove and insert pages as indicated below. New or changed text material is indicated by a vertical bar in the margin. An illustration change is indicated by a miniature pointing hand.

Remove pages

F-11 and F-12
F-25 and F-26

Insert pages

F-11 and F-12
F-25 and F-26

2. Retain this sheet in front of manual for reference purposes.

By Order of the Secretary of the Army:

Official:

DENNIS J. REIMER
General, United States Army
Chief of Staff

JOEL B. HUDSON
Acting Administrative Assistant to the
Secretary of the Army
00513

DISTRIBUTION:

To be distributed in accordance with DA Form 12-25-E, block no. 2482, requirements for TM 5-4930-234-13&P.

URGENT

CHANGE

NO. 4

HEADQUARTERS
DEPARTMENT OF THE ARMY
WASHINGTON, D.C., 6 March 1991

Operator, Organizational, and Direct Support
Maintenance Manual and Repair Parts and
Special Tools List

CLOSED CIRCUIT REFUELING NOZZLE
MODEL NUMBERS
NSN 4930-01-194-2625 (AE83206R)
NSN 4930-01-214-2909 (AE83501R)

Approved for public release; distribution is unlimited

TM 5-4930-234-13&P, 24 November 1986, is changed as follows:

1. Remove and insert pages as indicated below. New or changed text material is indicated by a vertical bar in the margin. An illustration change is indicated by a miniature pointing hand.

Remove pages

iii
5-27 and 5-28
5-29 and 5-30
B-5/(B-6 blank)
E-1 and E-2
F-19/(F-20 blank)

Insert pages

iii/(iv blank)
5-27 and 5-28
B-5/(B-6 blank)
E-1 and E-2
F-19/(F-20 blank)

2. Retain this sheet in front of manual for reference purposes.

By Order of the Secretary of the Army:

CARL E. VUONO
General, United States Army
Chief of Staff

Official:

THOMAS F. SIKORA
Brigadier General, United States Army
The Adjutant General

DISTRIBUTION:

To be distributed in accordance with DA Form 12-25E, (qty rqr block no. 2482)

CHANGE }
NO. 3 }

HEADQUARTERS
DEPARTMENT OF THE ARMY
WASHINGTON, D.C., 28 August 1989

**Operator, Organizational, and Direct Support
Maintenance Manual and Repair Parts and
Special Tools List**

**CLOSED CIRCUIT REFUELING NOZZLE
MODEL NUMBERS
NSN 4930-01-194-2625 (AE83206R)
NSN 4930-01-214-2909 (AE83501R)**

Approved for public release; distribution is unlimited.

TM 5-4930-234-13&P, 24 November 1986, is changed as follows:

1. Remove and insert pages as indicated below. New or changed text material is indicated by a vertical bar in the margin. An illustration change is indicated by a miniature pointing hand.

Remove pages

2-5 and 2-6
5-13 through 5-16
5-19 and 5-20
F-i through F-15/F-16
F-17 through F-20
F-21 through F-23/F-24
F-25 through F-27/F-28

Insert pages

2-5 and 2-6
5-13 through 5-16
5-19 and 5-20
F-1 through F-15/F-16
F-17 through F-19/F-20
F-21 through F-24

2. Retain this sheet in front of manual for reference purposes.

By Order of the Secretary of the Army:

CARL E. VUONO
General, United States Army
Chief of Staff

Official:

WILLIAM J. MEEHAN, II
Brigadier General, United States Army
The Adjutant General

DISTRIBUTION:

To be distributed in accordance with DA Form 12-25A, Operator, Unit, and Direct and General Support Maintenance requirements for Nozzle Assembly (4930-01-194-2625).

CHANGE

NO. 2

HEADQUARTERS
DEPARTMENT OF THE ARMY
WASHINGTON, D.C., 14 April 1988

**Operator, Organizational, and Direct Support
Maintenance Manual and Repair Parts and
Special Tools List**

**CLOSED CIRCUIT REFUELING NOZZLE
MODEL NUMBERS
NSN 4930-01-194-2625 (AE83206R)
NSN 4930-01-214-2909 (AE83501R)**

TM 5-4930-234-13&P, 24 November 1986, is changed as follows:

1. Remove and insert pages as indicated below. New or changed text material is indicated by a vertical bar in the margin. An illustration change is indicated by a miniature pointing hand.

Remove pages

i and ii
2-1 and 2-2
4-13 and 4-14
I-1 and I-2

Insert pages

i and ii
2-1 and 2-2
4-13 and 4-14
I-1 and I-2

2. Retain this sheet in front of manual for reference purposes.

By Order of the Secretary of the Army:

CARL E. VUONO
General, United States Army
Chief of Staff

Official:

R. L. DILWORTH
Brigadier General, United States Army
The Adjutant General

DISTRIBUTION:

To be distributed in accordance with DA Form 12-25A, Operator, Unit, and Direct and General Support Maintenance Requirements for Nozzle Assembly (4930-01-194-2625).

CHANGE }
NO. 1 }

HEADQUARTERS
DEPARTMENT OF THE ARMY
WASHINGTON, D.C., 1 May 1987

**Operator, Organizational, and Direct Support
Maintenance Manual and Repair Parts and
Special Tools List**

**CLOSED CIRCUIT REFUELING NOZZLE
MODEL NUMBERS
NSN 4930-01-194-2625 (AE83206R)
NSN 4930-01-214-2909 (AE83501R)**

TM 5-4930-234-13&P, 24 November 1986, is changed as follows:

1. Remove and insert pages as indicated below. New or changed text material is indicated by a vertical bar in the margin. An illustration change is indicated by a miniature pointing hand.

Remove pages

Insert pages

2-3 and 2-4

2-3 and 2-4

2. Retain this sheet in front of manual for reference purposes.

By Order of the Secretary of the Army:

Official:

R. L. DILWORTH
Brigadier General, United States Army
The Adjutant General

JOHN A. WICKHAM, JR.
General, United States Army
Chief of Staff

DISTRIBUTION:

To be distributed in accordance with DA Form 12-25A, Operator, Unit, and Direct and General Support Maintenance Requirements for Nozzle Assembly (4930-01-194-2625).

WARNING

Ground dip and ground plug must be attached before connecting nozzle to aircraft. Failure to comply can result in severe electric shock and injury or death to personnel.

WARNING

Aviation fuel is highly flammable. No smoking or open flames are permitted during fueling operations. Failure to comply can result in injury or death to personnel.

WARNING

Proper eye protection must be worn. Failure to comply can result in loss of eyesight.

WARNING

Never attempt to connect a nozzle with a unisex inlet (nozzle part number AE83501 R) to any coupling produced by a manufacturer other than Aeroquip Corporation. Failure to heed this warning could result in nozzle disconnecting and possible loss of aircraft and/or life.

WARNING

For refueling operations, confirm that the inlet coupling is stamped with part number AE70725R before using a nozzle with a unisex inlet coupling (nozzle part number AE83501 R). Failure to heed this warning could result in loss of aircraft and/or life.

FIRST AID FOR SOLDIERS FM 21-11

Change 6 a/(b blank)

**Operator's, Organizational, and Direct Support Maintenance Manual
and Repair Parts and Special Tools List
CLOSED CIRCUIT REFUELING NOZZLE
MODEL NUMBERS
NSN 4930-01-194-2625 (AE83206R)
NSN 4930-01-214-2909 (AE83501 R)**

REPORTING ERRORS AND RECOMMENDING IMPROVEMENTS

You can help improve this manual. If you find any mistakes, or if you know of a way to improve these procedures, please let us know. Mail your letter, DA Form 2028 (Recommended Changes to Publications and Blank Forms) or DA Form 2028-2 located in the back of this manual directly to: Commander, US Army Aviation and Troop Command, ATTN: AMSAT-I-MP, 4300 Goodfellow Blvd., St. Louis, MO 63120-1798. You may also submit your recommended changes by E-mail directly to <mpmt%/oavma28@st-louis-emh7.army.mil>. A reply will be furnished directly to you. Instructions for sending an electronic 2028 may be found at the back of this manual immediately preceding the hard copy 2028.

DISTRIBUTION STATEMENT A: Approved for public release; distribution is unlimited

TABLE OF CONTENTS

	PAGE
CHAPTER 2 INTRODUCTION	1-1
Section IV General Information	1-1
Section V Equipment Description and Data	1-1
Section VI Principles of Operation	1-3
CHAPTER 3 OPERATING INSTRUCTIONS	3-1
Section I Description and Use of Operator's Controls and Indicators.....	2-1
Section II Operator Preventive Maintenance Checks and Services	2-2
Section III Operation Under Usual Conditions	2-3
Section IV Operation Under Unusual Conditions	2-9
CHAPTER 4 OPERATOR MAINTENANCE INSTRUCTIONS	4-1
Section I Lubrication Instructions	3-1
Section II Troubleshooting Procedures.....	3-1
Section III Maintenance Procedures.....	3-2
CHAPTER 5 ORGANIZATIONAL MAINTENANCE INSTRUCTIONS.....	5-1
Section I Repair Parts, Special Tools; Test, Measurement, and Diagnostic Equipment (TMDE); and Support Equipment	4-1
Section II Service Upon Receipt	4-1
Section III Troubleshooting Procedures.....	4-1
Section IV Maintenance Procedures.....	4-4
Section V Preparation for Storage or Shipment	4-13
CHAPTER 6 DIRECT SUPPORT MAINTENANCE INSTRUCTIONS.....	6-1
Section I Troubleshooting Procedures.....	5-1
Section II Maintenance Procedures.....	5-5

Table of Contents (Continued)

	Page
APPENDIX A. REFERENCES	A-1
APPENDIX B. MAINTENANCE ALLOCATION CHART	B-1
APPENDIX C. COMPONENTS OF END ITEM/BASIC ISSUE ITEMS	C-1
APPENDIX D. ADDITIONAL AUTHORIZATION LIST	D-1
APPENDIX E. EXPENDABLE/DURABLE SUPPLIES AND MATERIALS LIST.....	E-1
APPENDIX F. REPAIR PARTS AND SPECIAL TOOLS LIST.....	F-1
INDEX.....	AI-1

LIST OF ILLUSTRATIONS

Figure	Title	Page
1-1	CCR Nozzle Assembly	1-0
2-1	Operating Controls	2-0
2-2.	Operation of Nozzle, Model AE83206R.....	2-4
2-3	Operation of Nozzle, Model AE835 01R.....	2-7
3-1	Cam-Lock Gasket Replacement	3-3
3-2	Unisex Seal Replacement	3-4
3-3	Strainer and O-ring Replacement.....	3-5
4-1	Dust Cap Assembly.....	4-4
4-2	Dust Plug Assembly	4-6
4-3	Ground Plug Assembly.....	4-8
4-4	Ground Clip Assembly.....	4-9
4-5	Cam-Lock Coupling Assembly	4-11
4-6	Unisex Coupling Assembly.....	4-12
5-1	Cam-Lock Coupling Removal	5-6
5-2	Cam Arm Disassembly.....	5-7
5-3	Cam Arm Assembly	5-7
5-4	Unisex Coupling Removal	5-8
5-5	Unisex Coupling Disassembly.....	5-9
5-6	CCR Nozzle Component Removal.....	5-11
5-7	CCR Nozzle Disassembly	5-13
5-8	Plunger Removal.....	5-14
5-9	Nose Sleeve Removal.....	5-16
5-10	Adapter Removal.....	5-16
5-11	Adapter Assembly	5-19
5-12	Removal of Release Pin Mechanism Tool	5-20
5-13	Body Installation	5-21
5-14	Tool Installation	5-21

LIST OF ILLUSTRATIONS (Continued)

Figure	Title	Page
5-15	Adapter Installation	5-22
5-16	Torquing Nose Sleeve	5-22
5-17	Piston and Rack Assembly	5-23
5-18	Handle and Thumb Latch Assembly	5-23
5-19	Plunger Assembly	5-24
5-20	Rack Positioning Tool	5-26
5-21	Pin Positioning Tool	5-26
5-22	Pinion Assembly	5-26
5-23	Ring Assembly	5-26
5-24	Deleted	■

LIST OF TABLES

Table	Title	Page
2-1	Operator Preventive Maintenance Checks and Services	2-3
3-1	Troubleshooting (Operator)	3-1
4-1	Troubleshooting (Organizational)	4-2
5-1	Troubleshooting (Direct Support)	5-1
5-2	Spring Dimensions	5-18

Change 4 iii/(iv blank)

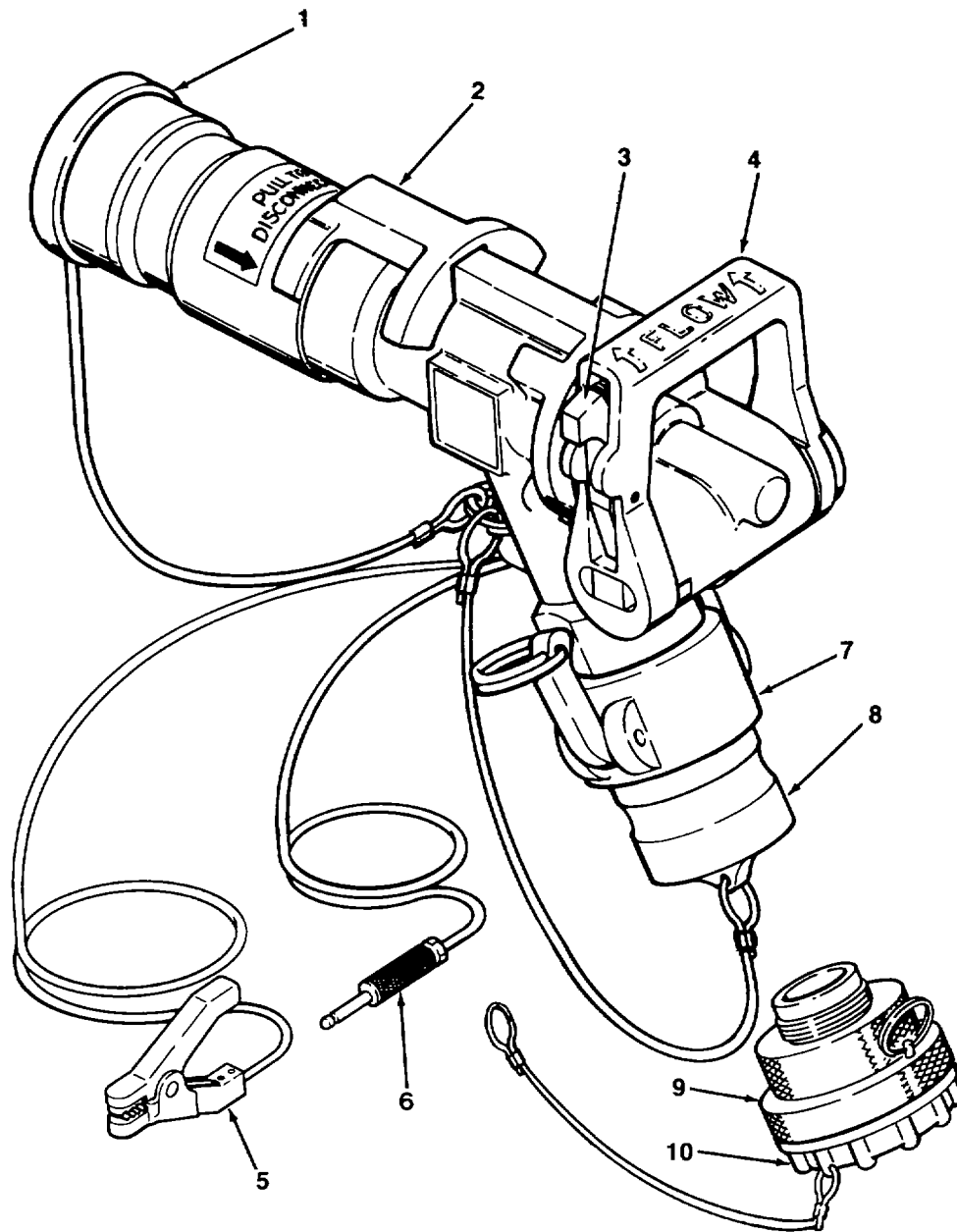

12536A

- 1. DUST CAP
- 2. PULLBACK SLEEVE
- 3. THUMB LATCH
- 4. FLOW HANDLE
- 5. GROUND CLIP

- 6. GROUND PLUG
- 7. CAM-LOCK COUPLING (AE83206R ONLY)
- 8. DUST PLUG (AE83206R ONLY)
- 9. UNISEX COUPLING (AE83501R ONLY)
- 10. DUST CAP (AE83501R ONLY)

Figure 1-1. CCR Nozzle Assembly

CHAPTER 1

INTRODUCTION

Section I. GENERAL INFORMATION

1-1. SCOPE. This Operator's, Organizational, and Direct Support Maintenance Manual and Repair Parts and Special Tools List covers operation, maintenance, test, and repair procedures for the Closed Circuit Refueling Nozzle (models AE83206R and AE83501R), hereafter referred to as "CCR nozzle", "nozzle assembly", or "nozzle". The purpose of the CCR nozzle is to dispense aviation fuel to aircraft.

1-2. MAINTENANCE FORMS, RECORDS, AND REPORTS. Department of the Army forms and procedures used for equipment maintenance will be those prescribed by DA PAM 738-750, The Army Maintenance Management System (TAMMS).

1-3. DESTRUCTION OF ARMY MATERIEL TO PREVENT ENEMY USE. This equipment shall be destroyed in accordance with TM 750-244-3, Procedures for Destruction of Equipment to Prevent Enemy Use.

1-4. PREPARATION FOR STORAGE OR SHIPMENT. See Chapter 4, Section V, Preparation For Storage or Shipment.

1-5. REPORTING EQUIPMENT IMPROVEMENT RECOMMENDATIONS (EIR'S). If your nozzle assembly needs improvement, let us know. Send us an EIR. You, the user, are the only one who can tell us what you don't like about your equipment. Let us know why you don't like the design or performance. Put it on a SF 368 (Quality Deficiency Report). Mail it to us at: Commander, U.S. Army Aviation and Troop Command, ATTN: AMSAT-I-MDO, 4300 Goodfellow Blvd., St. Louis, MO 63120-1798. We will send you a reply.

1-6. WARRANTY INFORMATION. The nozzle assembly is warranted by Aeroquip Corporation for one year from date of original delivery. Warranty starts on the date found on DA Form 2410 or DA Form 2408-16 in the logbook. Report all defects in material or workmanship to your supervisor who will take appropriate action.

Section II. EQUIPMENT DESCRIPTION AND DATA

1-7. EQUIPMENT CHARACTERISTICS, CAPABILITIES, AND FEATURES. (See Figure 1-1.)

CHARACTERISTICS:

- * Light weight. Can be hand carried to and from aircraft.
- * Manually operated.
- * Complete nozzle assembly. Includes protective caps and grounding connectors.

CAPABILITIES AND FEATURES:

Do not use nozzle to dispense low lead fuel. Failure to comply can result in damage to seals.

- * Will dispense aviation grade jet fuels to aircraft.
- * Inlet designed to connect to standard aircraft receptacle without use of additional adapters.
- * Model AE83206R will connect to standard cam-lock couplings.
- * Model AE83501R will connect to another unisex coupling.
- * Cam-lock and unisex couplings are interchangeable. All other parts and operating controls are identical.
- * Will not dispense fuel unless connected to aircraft receptacle.

1-8. EQUIPMENT DESCRIPTION AND DATA.

Manufacturer - Aeroquip Corporation
Models - AE83206R and AE83501R

Operating Temperature Range: -250F to 1250F (-320C to +520C)
Inlet Operating Pressure: 125 psig Maximum (862 kPag)
Outlet Operating Pressure (Handle in FLOW Position): 15 psig (105 kPag)
Flow Operating Range: 0 to 150 gpm (0 to 568 lpm)

Length - Handle in Flow Position:

- Nozzle Subassembly Only: 13 inches (331 mm)
- Nozzle with Coupling and Dust Cap, Model AE83206R: 13 1/2 inches (343 mm)
- Nozzle with Coupling and Dust Cap, Model AE83501R: 13 1/2 inches (343 mm)

Length - Handle in No Flow Position:

- Nozzle Subassembly Only: 15 1-2 inches (394 mm)
- Nozzle with Coupling and Dust Cap, Model AE83206R: 16 inches (407 mm)
- Nozzle with Coupling and Dust Cap, Model AE83501R: 16 inches (407 mm)

Width: 4 5/8 inches (117 mm)

Height - Handle in Flow Position:

- Nozzle Subassembly Only: 7 3/4 inches (197 mm)
- Nozzle with Coupling and Dust Cap, Model AE83206R: 9 3/4 inches (248 mm)
- Nozzle with Coupling and Dust Cap, Model AE83501R: 9 1/4 inches (235 mm)

Height - Handle in No Flow Position:

- Nozzle Subassembly Only: 6 1/2 inches (165 mm)
- Nozzle with Coupling and Dust Cap, Model AE83206R: 8 1/2 inches (216 mm)
- Nozzle with Coupling and Dust Cap, Model AE83501R: 8 inches (204 mm)

Weight:

- Nozzle Subassembly Only: 6.2 pounds (2.8 Kg)
- Nozzle with Coupling and Dust Cap, Model AE83206R: 8.4 pounds (3.8 Kg)
- Nozzle with Coupling and Dust Cap, Model AE83501R: 8.4 pounds (3.8 Kg)

1-9. NOMENCLATURE CROSS REFERENCE LIST.

Closed Circuit Refueling Nozzle - CCR nozzle, nozzle assembly, nozzle.
 Adapter Assembly - Unisex coupling, coupling.
 Cam-lock coupling - coupling.
 Handle - Flow Handle.

1-10. DIFFERENCES BETWEEN MODELS.

Model AE83206R: Equipped with cam-lock coupling and dust plug on inlet end.

Model AE83501R: Equipped with a unisex coupling and dust plug on inlet end.

1-11. SAFETY, CARE, AND HANDLING.

SAFETY:

- * Grounding connectors must be attached before connecting nozzle to aircraft receptacle. Failure to comply can result in injury or death to personnel.
- * No smoking or open flames are permitted in refueling areas. Failure to comply can result in injury or death to personnel.
- * Do not use a nozzle that is damaged and/or leaking fuel.

CARE AND HANDLING:

- * Keep handle in NO FLOW (off) position when not in use.
- * Keep dust cap and plug installed when not in use. Dirt or dust can damage internal seals.
- * Do not leave laying on ground. Dirt or dust can interfere with handle and/or pullback sleeve operation.
- * Hand carry to and from aircraft. Do not drag on the ground.
- * Keep exterior clean. Remove dirt, dust, mud or moisture.

Section III. PRINCIPLES OF OPERATION

See Chapter 2, Section I, Description and Use of Operator's Controls and Indicators.

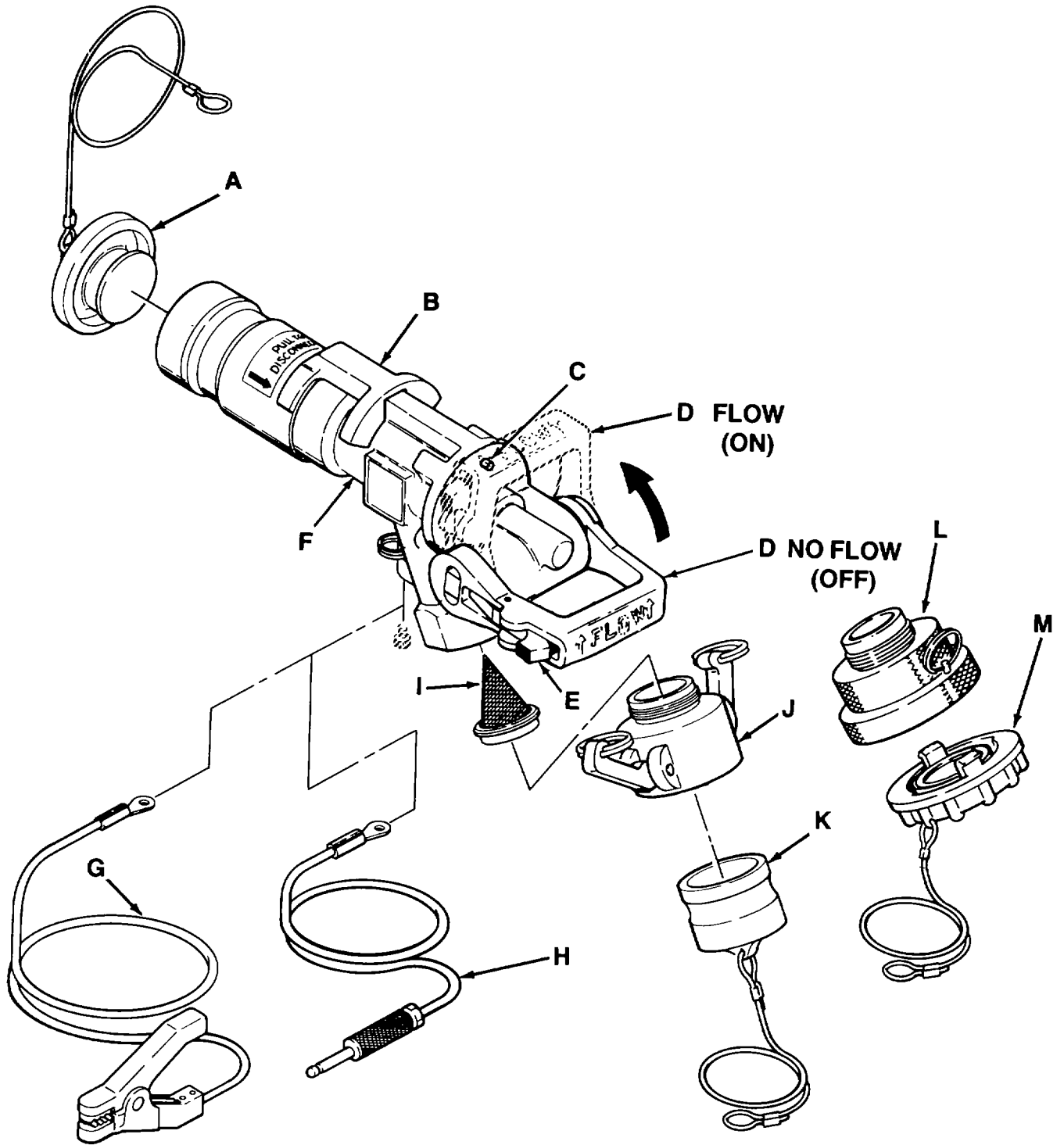

Figure 2-1. Operating Controls

CHAPTER 2

OPERATING INSTRUCTIONS

Section I. DESCRIPTION AND USE OF OPERATOR'S CONTROLS AND INDICATORS

2-1. OPERATING CONTROLS. (See Figure 2-1.)

- A. **DUST CAP.** Keeps dirt and foreign material out of nozzle body (F). To remove, pull pullback sleeve (B) toward handle (D).
- B. **PULLBACK SLEEVE.** Releases latches to attach nozzle to aircraft receptacle or dust cap (A). Pull towards handle (D) to release latches from aircraft receptacle or dust cap (A).
- C. **INDICATOR PIN.** Red color. Extends from nozzle body (F) to show aircraft fuel tank is full. Retracts flush with nozzle body (F) when pressure/flow stops.
- D. **HANDLE.** Used to control flow of fuel. Has two positions, FLOW (on) and NO FLOW (off). To change position, press thumb latch (E) and pull down (or up) on handle (D). Release thumb latch (E) to lock handle (D) in position.
- E. **THUMB LATCH.** Spring-loaded to lock handle (D) in FLOW (on) or NO FLOW (off) position. Press thumb latch (E) to move handle (D). Release thumb latch (E) to lock handle (D) in position.
- F. **NOZZLE BODY.** Internally regulates fuel flow.
- G. **GROUND CLIP.** Grounds aircraft to prevent static electric shock to personnel and fire hazards. Clamp to grounding rod near aircraft before connecting nozzle body (F) to aircraft.
- H. **GROUND PLUG.** Grounds aircraft to prevent static electric shock to personnel and fire hazards. Connect to aircraft before connecting nozzle body (F) to aircraft.
- I. **STRAINER.** Removes dirt and other foreign particles in fuel. Prevents material from damaging nozzle and/or aircraft.
- J. **CAN-LOCK COUPLING.** Used with model AE83206R only. Connects nozzle body (F) to fuel hose using a standard cam-lock connector. To install/remove fuel hose, or dust plug (K), pull cam arms away from coupling (J). To lock fuel hose or dust plug (K) to coupling, push cam arms against coupling (J).
- K. **DUST PLUG.** Used with model AE83206R only. Keeps dirt and foreign material out of nozzle body (F). To install or remove see cam-lock coupling (J).

- L. **UNISEX COUPLING.** Used with model AE83501R only. Connects nozzle body (F) to fuel hose using a unisex type connector. Equipped with a spring loaded locking pin to prevent separation of nozzle body (F) and fuel hose. To disengage locking pin, pull ring away from coupling (L). To install fuel hose, insert in coupling (L) and turn nozzle body (F) counterclockwise to lock. To remove fuel hose, pull ring and turn nozzle body (F) clockwise.
- M. **DUST CAP.** Used with model AE83501R nozzle only. Keeps dirt and foreign material out of nozzle body (F). To install, insert in unisex coupling (L) and turn clockwise. To remove, turn counterclockwise.

Section II. OPERATOR PREVENTIVE MAINTENANCE CHECKS AND SERVICES

2-2. GENERAL.

- a. The nozzle must be inspected to ensure it is ready for operation at all times. A systematic inspection will identify defects and allow them to be corrected before they can result in serious damage or failure.
- b. Defects discovered during operation of the nozzle shall be noted for future corrections. These corrections shall be done after operation has ceased, or as soon as possible. Stop operation which would damage the nozzle or aircraft.
- c. All deficiencies and shortcomings shall be recorded, together with corrective action taken, on DA form 2404, "Equipment Inspection and Maintenance Worksheet", as soon as possible.
- d. When performing Before Operation (B) and During Operation (D) PMCS, remember the CAUTIONS and WARNINGS. After operation, be sure to perform After Operation (A) PMCS. If the nozzle fails to operate, troubleshoot with proper equipment. Report any deficiencies using the proper form. Reference DA PAM 738-750.

2-3. PREVENTIVE MAINTENANCE CHECKS AND SERVICES. See Table 2-1 for Operator Preventive Maintenance Checks and Services.

- a. Item Number Column. Checks and services are numbered in chronological order regardless of interval. This column will be used as a source of item numbers for the "TM Item Number" column on DA Form 2404 in recording results of PMCS.
- b. Interval Columns. The columns headed "B", "D", "A", "W", and "M" will contain a dot(*) underneath the appropriate column, indicating PMCS is to be performed Before, During, After, Weekly, and/or Monthly.
- c. Item to be Inspected Column. The items listed in this column are divided into groups and identify the items to be inspected.
- d. Procedures Column. This column contains a brief description of the procedure by which the check is to be performed.
- e. For Readiness Reporting, Equipment is Not Ready/Available If: Column. This column will contain the criteria which will cause the equipment to be classified as not Ready/Available because of inability to perform its primary mission.

NOTE

If nozzle must be kept in continuous operation, check and service only those items that can be checked and serviced without disturbing operation. Make a complete checks and services when nozzle can be shut down.

Table 2-1. Operator Preventive Maintenance Checks and Services

NOTE: Within designated interval, these checks are to be performed in the sequential order listed.

Item No.	Interval					Procedures	Check For and Have Repaired or Adjusted	For Readiness Reporting, Equipment is Not Ready/Available if:
	B	D	A	W	M			
1.	*	*	*		*	Nozzle Assy	Check for damaged body, signs of leaks or cracks.	Outward signs of damage.
2.		*		*	*	Cap Assy	Check for signs of cracks, loose or frayed cable.	N/A
3.	*	*	*		*	Ground Clip Assy	Check for loose or frayed cable. Check for damage to clip or cable eye.	Outward signs of damage.
4.	*		*		*	Coupling Assy	Check for signs of cracks, loose or frayed cable. Check to ensure coupling gasket is in place.	Outward signs of damage.
5.	*	*	*			Cam-Lock Coupling	Check for loose coupling or signs of leakage.	Cam-Lock Coupling is loose or leaking or shows signs of leakage.
6.	*	*	*		*	Ground Plug Assy	Check for loose or frayed cable. Check for damage to plug or cable eye.	Outward signs of damage.
7.	*		*		*	Strainer	Check for damaged and/or dirty screen.	N/A

Section III. OPERATION UNDER USUAL CONDITIONS

2-4. CONNECTION OF NOZZLE, MODEL AE83206R. (See Figure 2-2.)

1. Pull cam arms (1) away from coupling (2).
2. Remove dust plug (3) from coupling (2).
3. Slide end of fuel hose (4) into coupling (2).
4. Push cam arms (1) against coupling (2).

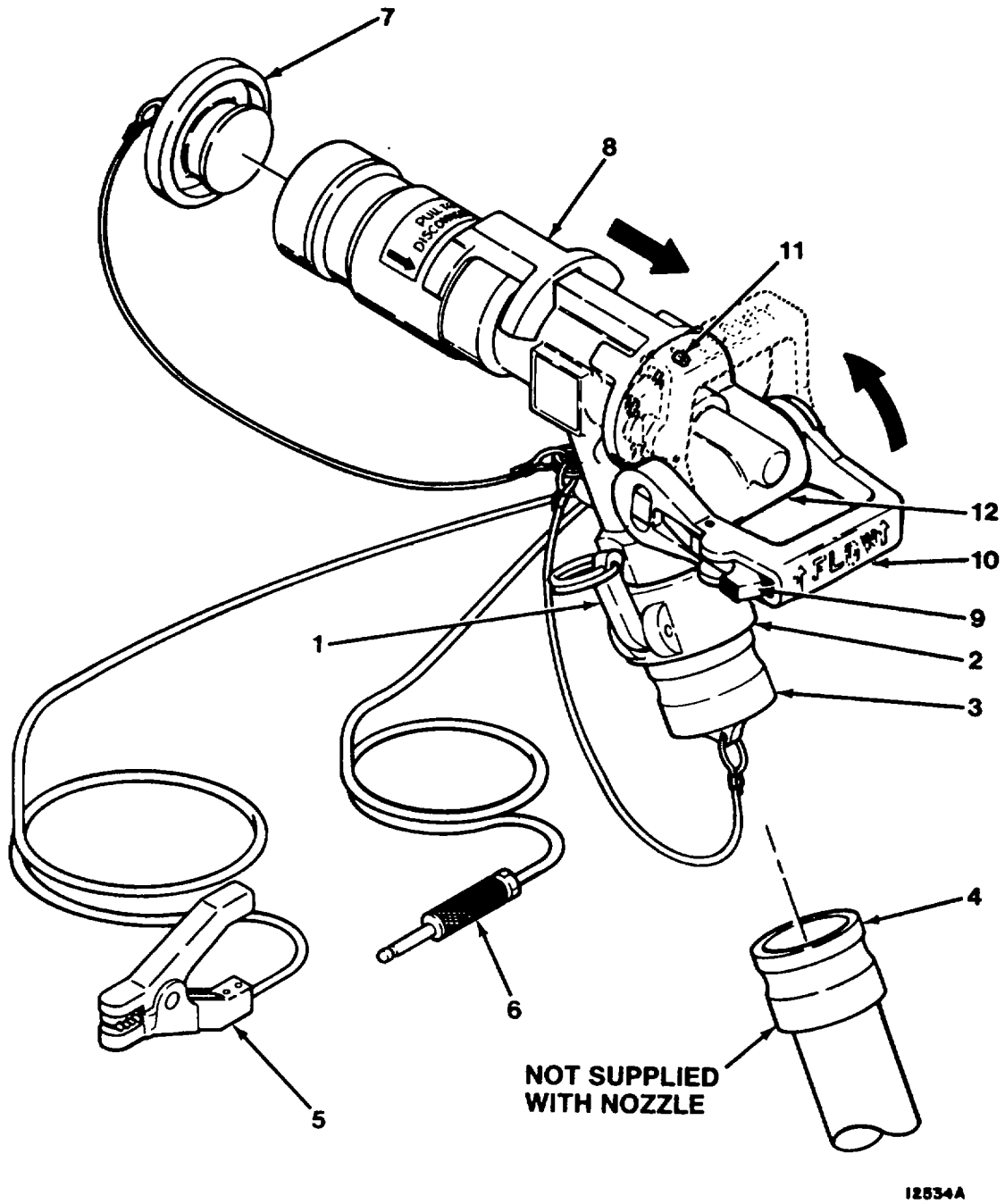

Figure 2-2. Operation of Nozzle, Model AE83206R

2-5. OPERATION OF NOZZLE, MODEL AE83206R**WARNING**

Ground dip and ground plug must be attached before connecting nozzle to aircraft. Failure to comply can result in severe electric shock and injury or death to personnel.

1. As required, uncoil cable on ground dip (5). Connect ground dip (5) to grounding rod.
2. As required, uncoil cable on ground plug (6). Connect ground plug (6) to aircraft.

WARNING

Aviation fuel is highly flammable. No smoking or open flames are permitted during fueling operations. Failure to comply can result in injury or death to personnel.

3. Wipe area around fuel receptacle with a dean lint-free cloth to remove dust or foreign material.
4. Remove fuel cap from aircraft fuel receptacle.
5. Pull pullback sleeve (8) towards handle (10) and remove dust cap (7).
6. Attach nozzle (12) to aircraft fuel receptacle.
7. Press thumb latch (9). Move handle (10) up to FLOW (on) position.
8. Operate fuel pump to dispense fuel to aircraft.
9. Watch indicator pin (11). When it extends from the nozzle (12), shut off fuel pump.

NOTE

For multi-refueling operations, fuel pump does not have to be shut off.

10. Press thumb latch (9). Move handle (10) down to NO FLOW (off) position. Release handle (10).

CAUTION

Nozzle must be removed by pulling straight out from receptacle. Failure to remove properly may cause damage to receptacle mounting.

11. Pull pullback sleeve (8) toward handle (10). Remove nozzle (12) from receptacle by pulling straight out.

NOTE

A firm pull is required to remove nozzle assembly away from fuel receptacle.

12. Wipe inside of dust cap (7), nozzle (12), and fuel receptacle with a dean lint-free cloth to remove dust, dirt or fuel.
13. Install fuel cap on aircraft fuel receptacle.
14. Install dust cap (7) on end of nozzle (12) by pulling pullback sleeve (8) toward handle.
15. Disconnect ground plug (6) from aircraft. As required, coil ground plug cable.
16. Disconnect ground dip (5) from grounding rod. As required, coil ground dip cable.

17. Wipe exterior of nozzle (12) and cables with a dean, lint-free cloth to remove dust, dirt, moisture, or fuel.



Do not leave nozzle laying on ground. Failure to comply can result in damage to nozzle.

18. Place nozzle (12) in a storage container away from aircraft

2-6. DISCONNECTION OF N0771 F, MODEL AE83206R.

NOTE

Have a suitable container available to catch any fuel spillage.

1. pull cam arms (1) away from coupling (2).
2. Remove fuel hose (4) from coupling (2).
3. Slide end of dust plug (3) into coupling (2).
4. Push cam arms (1) against coupling (2).

2-7. CONNECTION OF NOZZLE, MODEL AF83501R. (FIRGURE 2-3).

WARNING

Never attempt to connect a nozzle with a unisex inlet (nozzle part number AE83501 R) to any coupling produced by a manufacturer other than Aeroquip Corporation. Failure to heed this warning could result in nozzle disconnecting and possible loss of aircraft and/or life.

WARNING

For refueling operations, confirm that the inlet coupling is stamped with part number AE70725R before using a nozzle with a unisex inlet coupling (nozzle part number AE83501 R). Failure to heed this warning could result in loss of aircraft and/or life.

1. Turn dust cap (1) counterclockwise and remove from coupling (2).
2. Insert end of fuel hose (4) in coupling (2).
3. Turn fuel hose (4) clockwise to lock with coupling (2).
4. Turn handle (5) on fuel hose coupling to FLOW position.

2-8. OPERATION OF NOZZLE, MODEL AE3501R

WARNING

Ground dip and ground plug must be attached before connecting nozzle to aircraft. Failure to comply can result in severe electric shock and injury or death to personnel.

1. As required, uncoil cable on ground dip (6). Connect ground dip (6) to grounding rod.

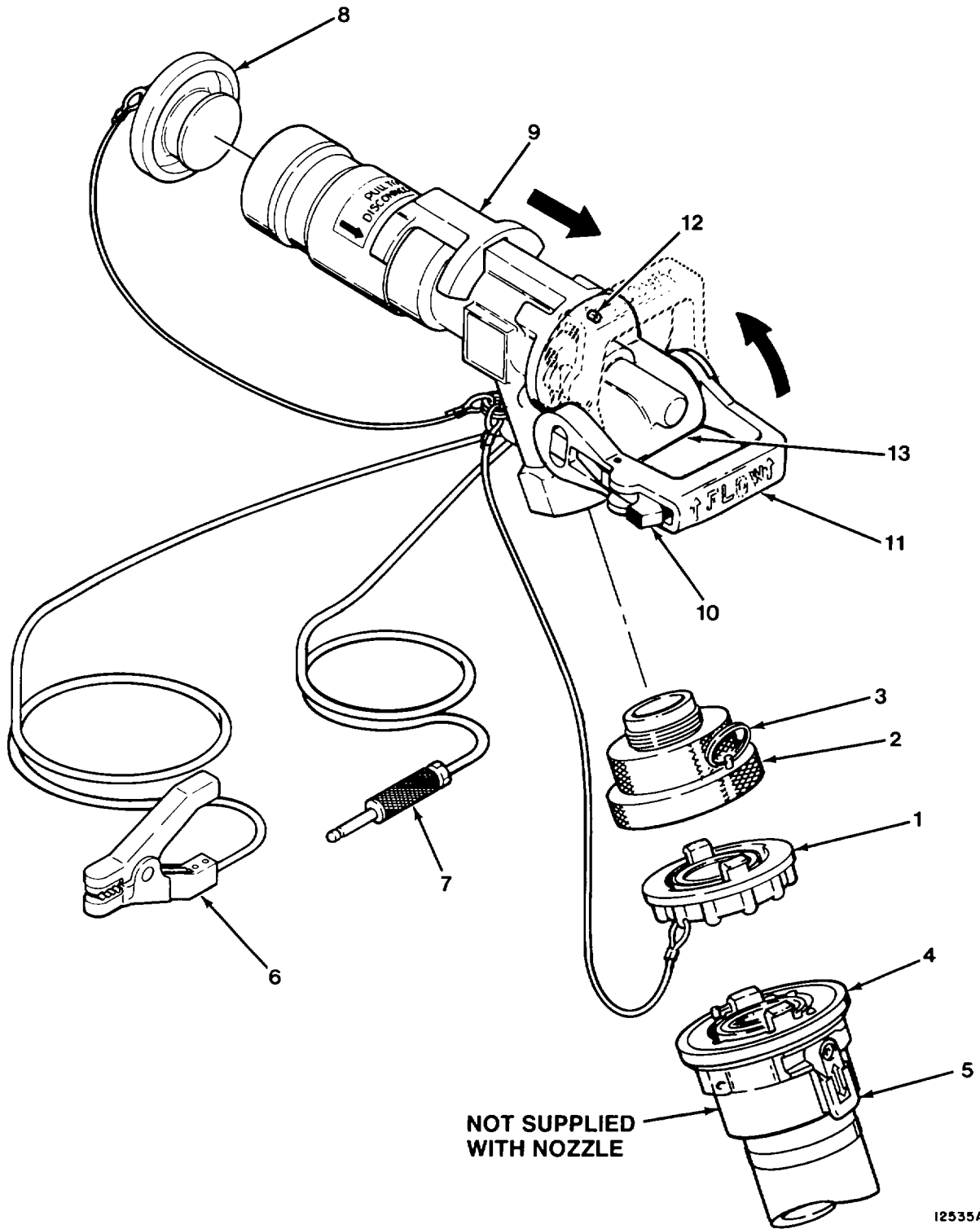

Figure 2-3. Operation of Nozzle, Model AE83501R

2. As required, uncoil cable on ground plug (7). Connect ground plug (7) to aircraft.

WARNING

Aviation fuel is highly flammable. No smoking or open flames are permitted during fueling operations. Failure to comply can result in injury or death to personnel.

3. Wipe area around fuel receptacle with a clean lint-free cloth to remove dust or foreign material.
4. Remove fuel cap from aircraft fuel receptacle.
5. Pull pullback sleeve (9) towards handle (11) and remove dust cap (8).
6. Attach nozzle (13) to aircraft fuel receptacle.
7. Press thumb latch (10). Move handle (11) up to FLOW (on) position.
8. Operate fuel pump to dispense fuel to aircraft.
9. Watch indicator pin (12). When it extends from the nozzle (13), shut off fuel pump.

NOTE

For multi-refueling operations, fuel pump does not have to be shut off.

10. Press thumb latch (10). Move handle (11) down to NO FLOW (off) position. Release handle (11).
11. Pull pullback sleeve (9) toward handle (11). Remove nozzle (13) from fuel receptacle.

NOTE

A firm pull is required to remove nozzle assembly away from fuel receptacle.

12. Wipe inside of dust cap (8), nozzle (13), and fuel receptacle with a clean, lint-free cloth to remove dust, dirt or fuel.
13. Install fuel cap on aircraft fuel receptacle.
14. Install dust cap (8) on end of nozzle (13) by pulling pullback sleeve (9) toward handle.
15. Disconnect ground plug (7) from aircraft. As required, coil ground plug cable.
16. Disconnect ground clip (6) from grounding rod. As required, coil ground clip cable.

17. Wipe exterior of nozzle (13) and cables with a clean, lint-free cloth to remove dust, dirt, moisture, or fuel.



Do not leave nozzle laying on ground. Failure to comply can result in damage to nozzle.

18. Place nozzle (13) in a storage container away from aircraft.

2-9. DISCONNECTION OF NOZZLE, MODEL AE83501R.

NOTE

Have a suitable container available to catch any fuel spillage.

1. Turn handle (5) on fuel hose coupling to NO FLOW position.
2. Pull ring (3) on coupling (2). Turn nozzle (11) clockwise and remove from fuel hose (4). Release ring (3).
3. Install dust cap (1) on coupling (2). Turn dust cap (1) clockwise to lock in place.

Section IV. OPERATION UNDER UNUSUAL CONDITIONS

2-10. OPERATION IN UNUSUAL CONDITIONS. The operating instructions for usual conditions are acceptable. Operators must take special care in the following areas.

a. Exterior Cleanliness. Wipe the nozzle, dust caps, dust plugs, and cables with a clean, lint-free cloth to remove dust, dirt, fuel, moisture, snow, or mud. Moisture, snow, and mud can clog or freeze in pullback sleeve and/or handle. Never store nozzle if dirty or wet.

b. Dust Caps and Dust Plugs. When not in use, keep dust caps and dust plugs installed. Dust, dirt, moisture, or mud can contaminate or damage internal seals. Never install dust caps or dust plugs when dirty or wet.

c. Storage. When not in use, keep nozzle stored in an area that will protect it from extreme temperatures, dust, dirt, mud, and physical damage.

2-9/(2-10 Blank)

CHAPTER 3

OPERATOR MAINTENANCE INSTRUCTIONS

Section I. LUBRICATION INSTRUCTIONS

No lubrication is required for operation of this equipment.

Section II. TROUBLESHOOTING PROCEDURES

3-1. GENERAL.

a. This section contains troubleshooting information for locating and correcting most of the operating troubles which may develop in the nozzle. Each malfunction for an individual component is followed by a list of tests or inspections which will help to determine corrective actions to take. Perform tests/inspections and U corrective actions in the order listed.

b. This manual cannot list all malfunctions that may occur, nor all tests or inspections and corrective actions. If a malfunction is not listed or is not corrected by listed corrective actions, notify your supervisor.

3-2. TROUBLESHOOTING. Table 3-1 lists the common malfunctions which may occur during operation or maintenance of the nozzle. Perform test/inspections and corrective actions in the order listed.

NOTE

Before using this table, be sure all applicable operating checks have been performed.

Table 3-1. Troubleshooting

MALFUNCTION	TEST OR INSPECTION	CORRECTIVE ACTION
1. HANDLE FAILS TO OPERATE SMOOTHLY.	Inspect handle area for signs of dirt or other foreign matter.	Clean area around handle.
2. LEAKAGE FROM COUPLING.	Step 1. Remove nozzle from fuel hose. Inspect inside coupling to ensure gasket or seals are in place. Inspect gasket or seals for cuts, tears, or distortion.	If gasket or seals are missing or damaged, install a new gasket or seals in coupling.

Table 3-1. Troubleshooting (cont)

MALFUNCTION	TEST OR INSPECTION	CORRECTIVE ACTION
	Step 2. Remove coupling from nozzle. Inspect coupling to ensure o-ring is in place. Inspect o-ring for cuts, tears, or distortion.	If o-ring is missing or damaged, install a new o-ring on coupling. Install coupling in nozzle. Hand-tighten only.
3. INADEQUATE FUEL FLOW.	Step 1. Remove coupling and strainer from nozzle. Check strainer for dirt or other foreign matter. Clean strainer by removing all dirt and foreign matter.	
	Step 2. While strainer is removed, inspect for any damage.	Replace strainer if damaged. Install strainer in nozzle, then install coupling. Hand-tighten only.

Section III. MAINTENANCE PROCEDURES

3-3. GENERAL. This section consists of inspection, service, or replacement of those items which would cause malfunction or hazardous operation of the nozzle.

3-4. CAN-LOCK COUPLING GASKET (See Figure 3-1).

a. Removal.

1. Shut fuel off at source. Place handle down in NO FLOW (off) position.

NOTE

Have a suitable container available to catch any fuel spillage.

2. Pull cam arms (2) away from coupling (3). Remove nozzle (1) from fuel hose.
3. Remove gasket (4) from inside coupling (3).

b. Inspection. Inspect gasket (4) for cuts, tears or distortion.

c. Replacement. Replace gasket (4) if damaged.

d. Reassembly.

1. Place gasket (4) inside coupling (3).
2. Attach fuel hose to nozzle (1). Push cam arms (2) toward coupling (3).

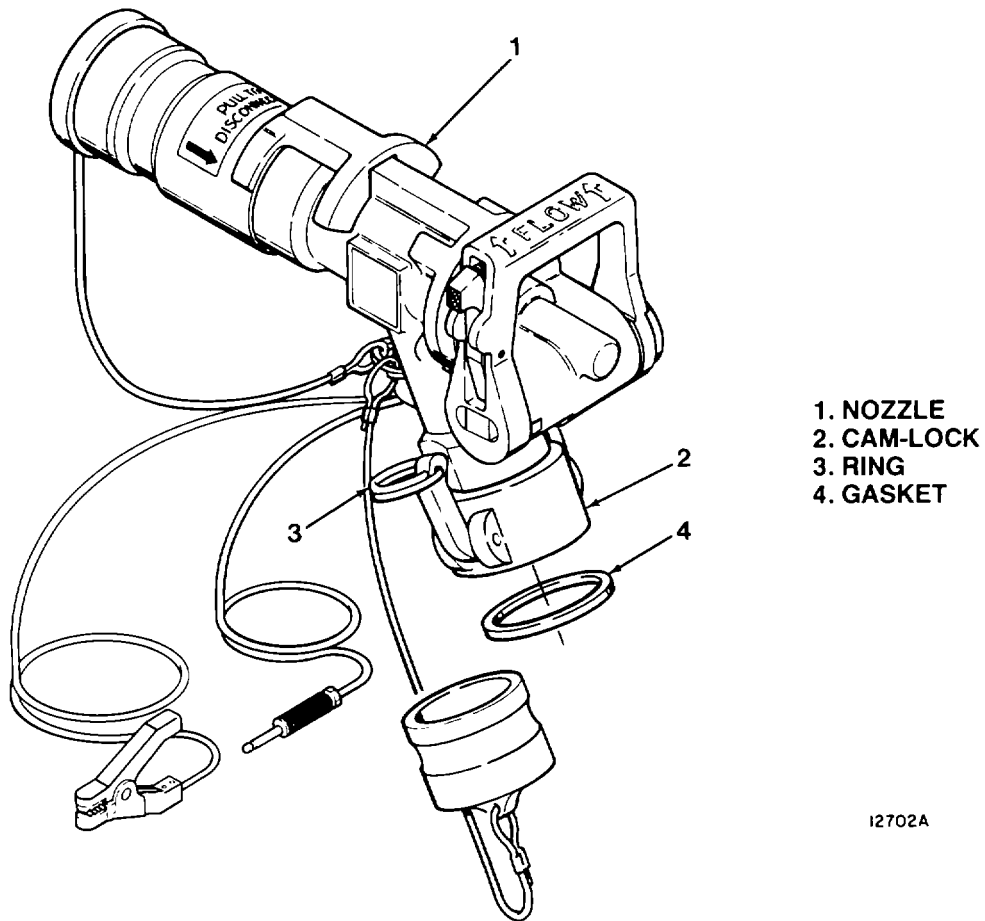

12702A

Figure 3-1. Cam-Lock Gasket Replacement

3-5. UNISEX COUPLING SEALS (See Figure 3-2).

a. Removal.

1. Shut fuel off at source. Place handle down in NO FLOW (off) position.

NOTE

Have a suitable container available to catch any fuel spillage.

2. Place handle (6), on fuel hose coupling, in NO FLOW position.
3. Pull ring (3) toward nozzle (1). Turn nozzle (1) clockwise and remove from fuel hose.
4. Remove seals (4) from inside coupling (2).

b. Inspection. Inspect seals (4) on coupling and dust cap for cuts, tears, or distortion.

c. Replacement. Replace seals (4) if damaged.

d. Reassembly.

1. Place seals (4) inside coupling (2) and dust cap.
2. Connect nozzle (1) to fuel hose and turn counterclockwise to lock in place.
3. Reconnect nozzle to fuel hose and turn handle (6) to FLOW position to operate nozzle.

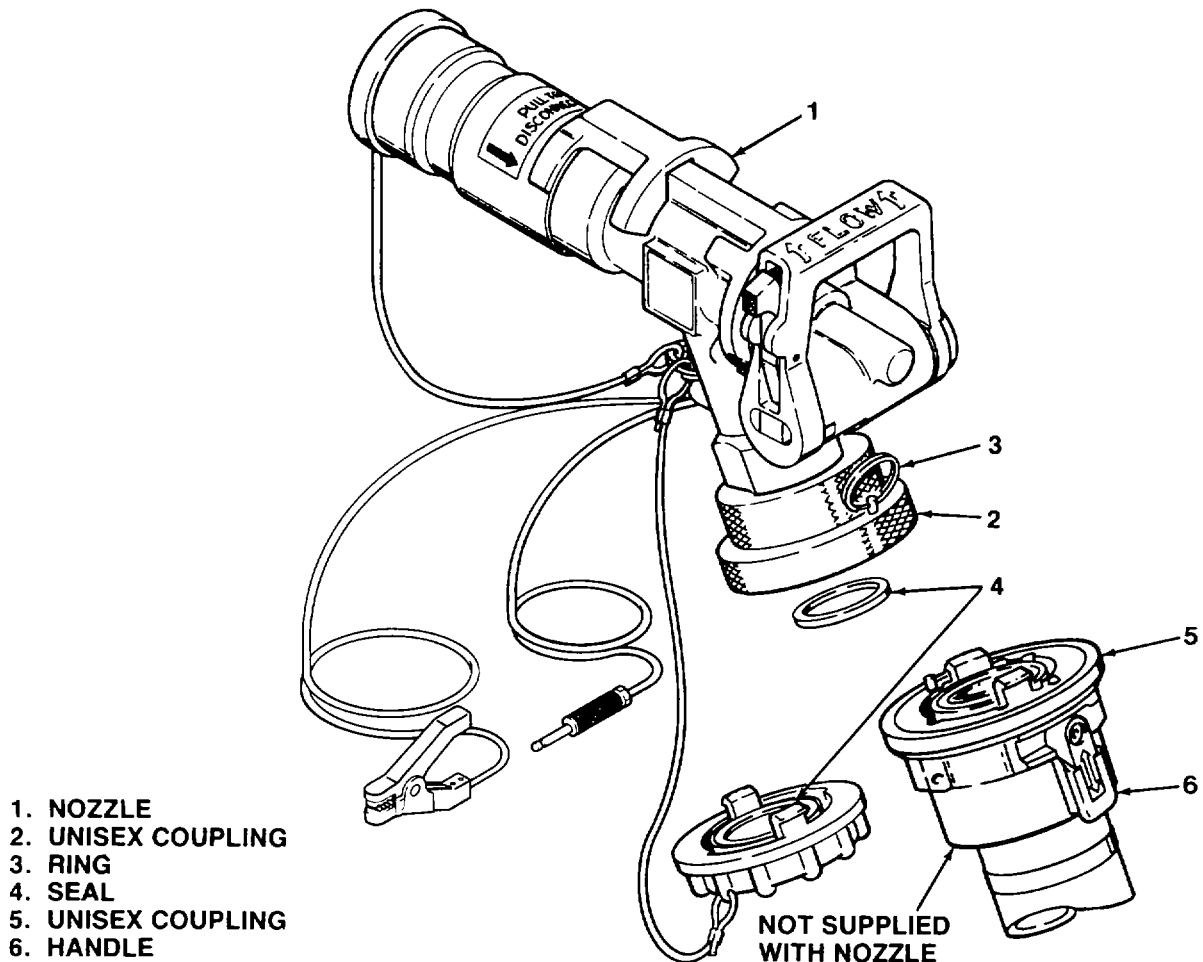

Figure 3-2. Unisex Seal Replacement

3-6. STRAIEKR AND O-RING (See Figure 3-3).

a. Removal.

1. Remove nozzle (1) from fuel hose per paragraph 3-4 (for a cam-lock coupling) or 3-5 (for a unisex coupling).
2. Turn coupling (2) counterclockwise to unthread from nozzle (1).

3. Pull strainer (3) out of nozzle (1).

b. Inspection. Inspect strainer (3) for cracks, distortion, or damage to screen. Inspect o-ring (4) on coupling for damage. Remove o-ring (4) if damaged.

c. Replacement. Replace strainer (3) or o-ring (4) if damaged.

d. Reassembly.

1. Place strainer (3) inside nozzle (1).

2. Thread coupling (2) into nozzle (1) and hand-tighten.

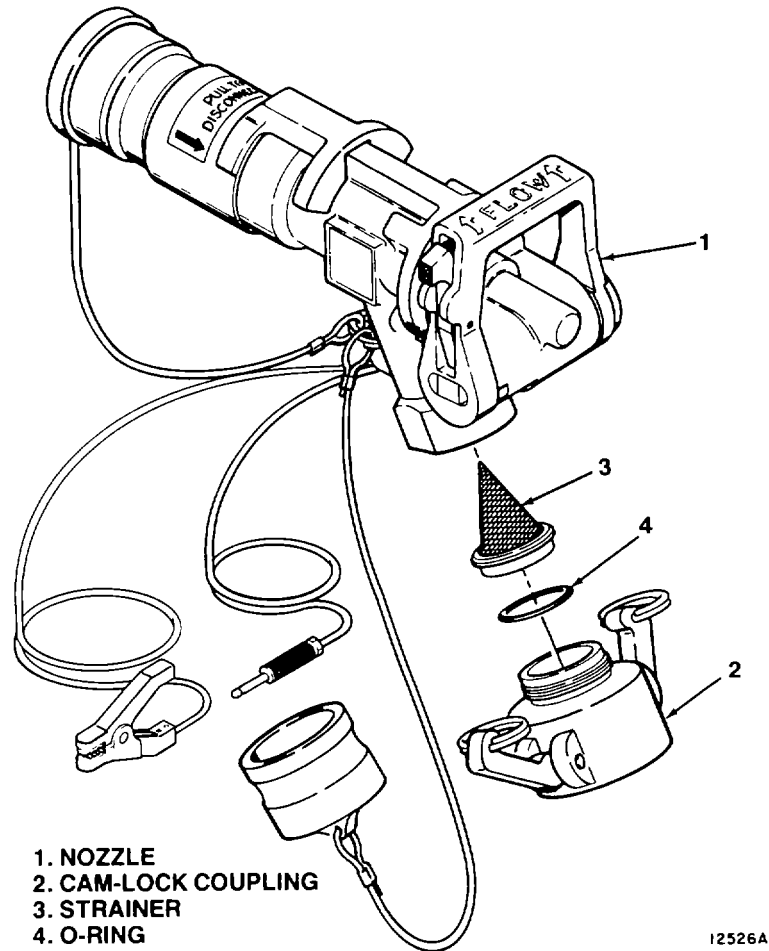

Figure 3-3. Strainer and O-ring Replacement

3-5/(3-6 Blank)

CHAPTER 4

ORGANIZATIONAL MAINTENANCE INSTRUCTIONS

Section I. REPAIR PARTS, SPECIAL TOOLS; TEST, MEASUREMENT AND DIAGNOSTIC EQUIPMENT (TMDE); AND SUPPORT EQUIPMENT.

All references to these items can be found in Appendices B through F.

Section II. SERVICE UPON RECEIPT**4-1. UNPACKING.**

- a. Remove any shipping receipts or documents attached to the outside of the container.
- b. Carefully open the container and remove any protective packing material.
- c. Remove nozzle from container.

4-2. INSPECTION.

- a. Inspect nozzle body for signs of damage or broken parts.
- b. Inspect dust cap, dust plug, ground clip, and ground plug for damage and attachment to nozzle.
- c. Report any damaged or missing parts to your supervisor immediately.

Section III. TROUBLESHOOTING PROCEDURES**4-3. GENERAL.**

a. This section contains troubleshooting information for locating and correcting most of the operating troubles which may develop in the nozzle. Each malfunction for an individual component is followed by a list of tests or inspections which will help to determine corrective actions to take. Perform the tests/inspections and corrective actions in the order listed.

b. This manual cannot list all malfunctions that may occur, nor all tests or inspections and corrective actions. If a malfunction is not listed or is not corrected by the listed corrective actions, notify your supervisor.

4-4. TROUBLESHOOTING. Table 4-1 lists the common malfunctions which may occur during operation or maintenance of the nozzle. Perform test/inspections and corrective actions in the order listed.

NOTE

Before using this table, be sure all applicable operating checks have been performed.

Table 4-1. Troubleshooting

MALFUNCTION	TEST OR INSPECTION	CORRECTIVE ACTION
1. DUST CAP ASSEMBLY DAMAGED.	Step 1. Inspect dust cap for corrosion, cracks, or distortion. If damaged, remove from cable and install new dust cap. Step 2. Inspect cable for corrosion, cuts, fraying and crimp of sleeves to cable. If damaged, remove from dust cap and nozzle. Install new cable and sleeves.	
2. DUST PLUG ASSEMBLY DAMAGED.	Step 1. Inspect dust plug for corrosion, cracks, or distortion. If damaged, remove from cable. Install new dust plug. Step 2. Inspect cable for corrosion, cuts, fraying, and crimp of sleeves to cable. If damaged, remove from dust plug and nozzle. Install new cable and sleeves.	
3. GROUND PLUG ASSEMBLY DAMAGED.	Step 1. Inspect ground plug for corrosion, cracks, or distortion. If damaged, remove from cable. Install new ground plug. Step 2. Inspect cable and cable eye for corrosion, cuts, fraying and crimp of sleeves to cable. If damaged, remove from ground plug. Install new cable, cable eye, and sleeves.	
4. GROUND CLIP ASSEMBLY DAMAGED.	Step 1. Inspect ground clip for corrosion, cracks, or distortion. If damaged, remove from cable. Install new ground clip.	

Table 4-1. Troubleshooting (cont)

MALFUNCTION	TEST OR INSPECTION	CORRECTIVE ACTION
Step 2. Inspect cable and cable eye for corrosion, cuts, fraying, and crimp of sleeves to cable.	If damaged, remove from ground clip and nozzle. Install new cable, cable eye and sleeves.	
5. CAM-LOCK COUPLING ASSEMBLY LEAKING.	Remove nozzle from fuel hose. Remove coupling from nozzle. Inspect coupling to ensure o-ring is in place. Inspect o-ring for cuts, tears, or distortion.	If o-ring is missing or damaged install new o-ring on coupling. If coupling still leaks install a new coupling.
6. UNISEX DUST CAP DAMAGED.	Step 1. Inspect dust cap for corrosion, cracks, or distortion.	If damaged, remove from cable. Install new dust cap.
Step 2. Inspect cable for corrosion, cuts, fraying, and crimp of sleeves to cable.	If damaged, remove from dust cap and nozzle. Install new cable and sleeves.	
7. UNISEX COUPLING ASSEMBLY LEAKING.	Remove nozzle from fuel hose. Inspect coupling to ensure seal is in place. Inspect seal for cuts, tears, or distortion.	If seal is missing or damaged install new seal in coupling. If coupling still leaks install a new coupling.
8. LEAKAGE AT OUTLET END.	Step 1. Inspect outlet end for dirt, foreign matter, or damage.	Remove dirt or foreign matter with a clean, lint free cloth. If there is any sign of damage send nozzle to Direct Support for overhaul.

Section IV. MAINTENANCE PROCEDURES

4-5. GENERAL. This section consists of inspection, service, or replacement of those items which would cause malfunction or hazardous operation of the nozzle. Remove nozzle from fuel hose before doing any of these procedures. Refer to paragraphs 3-4 or 3-5 for details.

4-6. DUST CAP ASSEMBLY (See Figure 4-1).**a. Removal.**

1. Hold nozzle (1) and pull back on pullback sleeve (2).
2. Remove dust cap (4) from end of nozzle (1).
3. Remove cable (6) from ring (3) on nozzle (1).

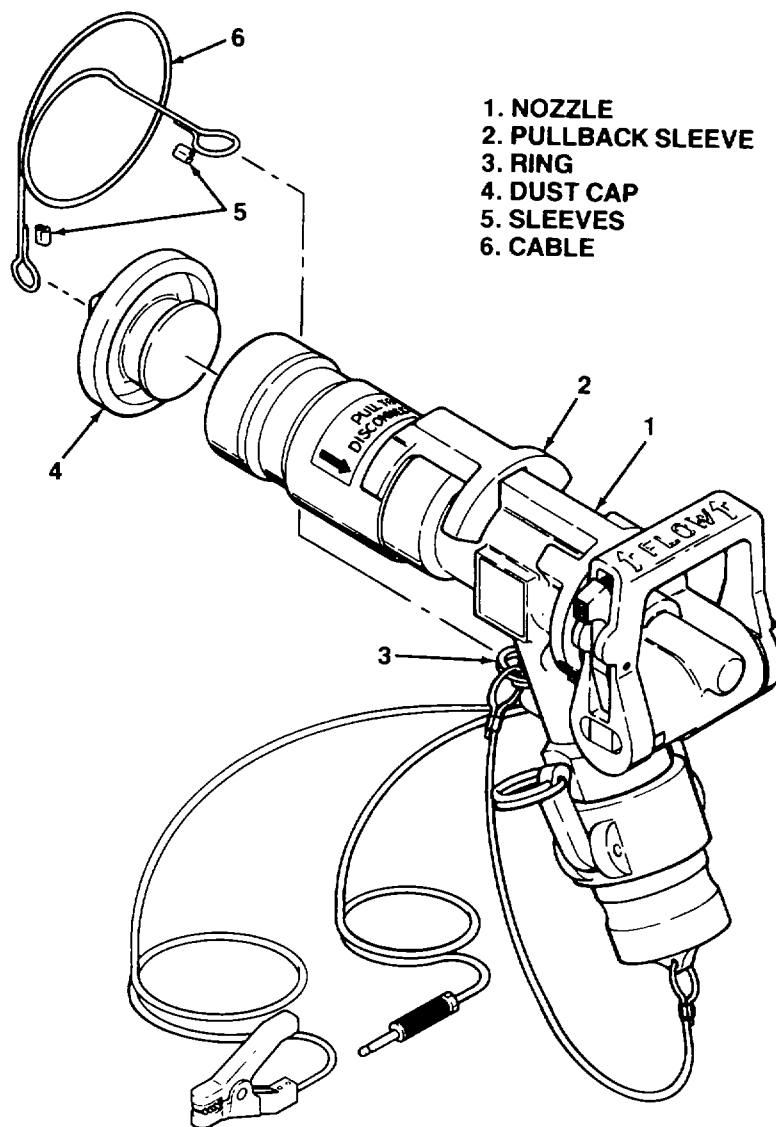

Figure 4-1. Dust Cap Assembly

- b. Disassembly.** Cut cable (6) near sleeve (5) at dust cap (4) and remove.

NOTE

Clean parts with a clean cloth to remove dust, dirt, fuel or grease.

- c. Inspection.**

1. Inspect dust cap (4) for corrosion, cracks, or distortion.
2. Inspect cable (6) for corrosion, cuts, or fraying.

- d. Replacement.** Replace any damaged parts.

- e. Reassembly.**

1. Slide sleeve (5) down cable (6).
2. Insert one end of cable (6) through hole in dust cap (4).
3. Make a one inch loop with the cable (6) and slide sleeve (5) over end of cable (6).
4. Crimp sleeve (5) in place on cable (6).
5. Repeat steps 1 through 4 for other end of cable (6).

- f. Installation.**

1. Install dust cap (4) on outlet end of nozzle (1).
2. Install end of cable (6) on ring (3).

4-7. DUST PLUG ASSI4BLY (See Figure 4-2).

- a. Removal.**

1. Hold nozzle (1) and pull cam arms (2) away from nozzle (1).
2. Remove dust plug (4) from end of nozzle (1).
3. Remove cable (6) from ring (3) on nozzle (1).

- b. Disassembly.** Cut cable (6) near sleeve (5) at dust plug (4) and remove.

NOTE

Clean parts with a clean cloth to remove dust, dirt, fuel or grease.

- c. Inspection.**

1. Inspect dust plug (4) for corrosion, cracks, or distortion.

2. Inspect cable (6) for corrosion, cuts, or fraying.
- d. **Replacement.** Replace any damaged parts.
- e. **Reassembly.**
1. Slide sleeve (5) down cable (6).
 2. Insert one end of cable (6) through hole in dust cap (4).

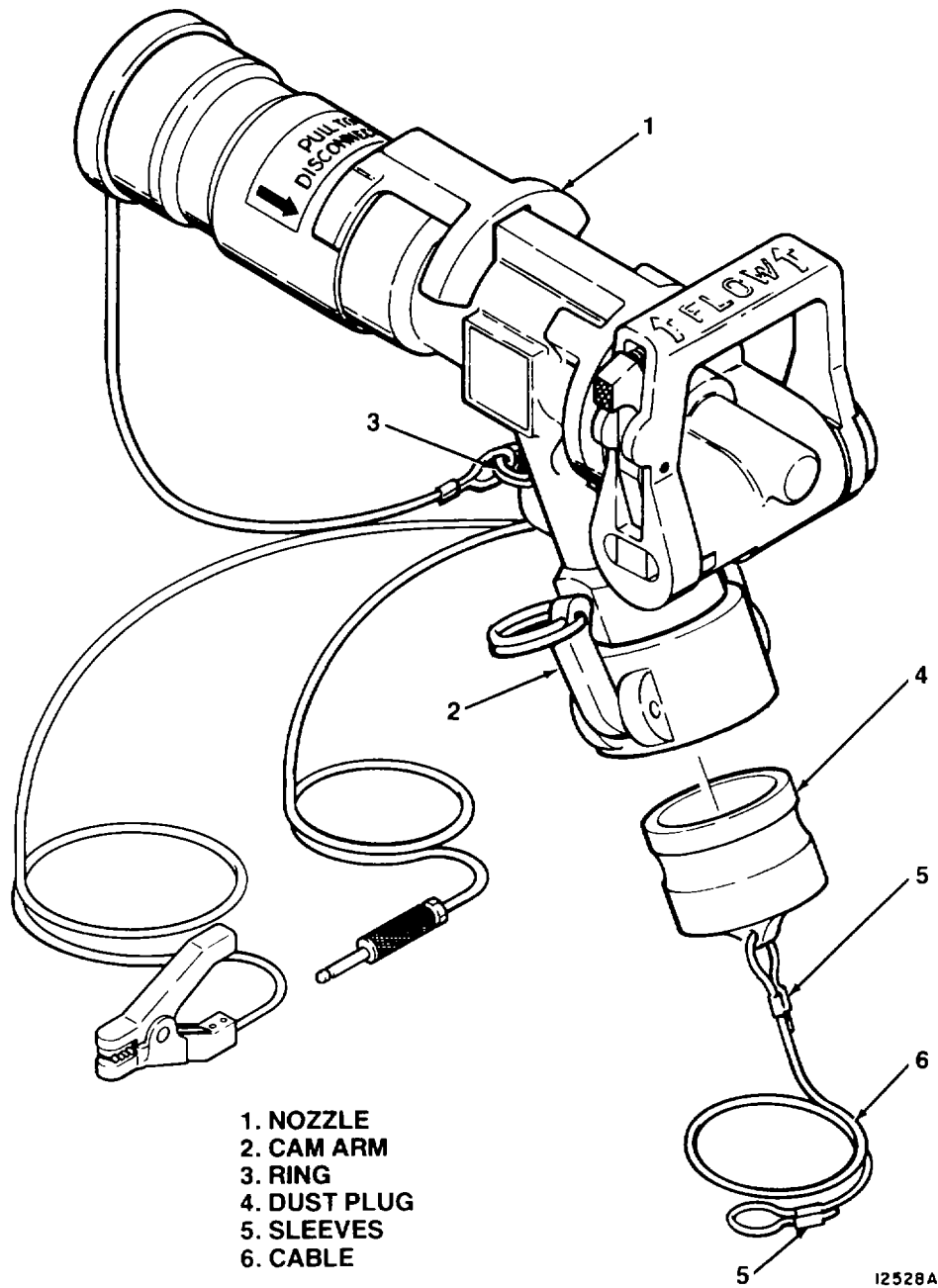

Figure 4-2. Dust Plug Assembly

3. Make a one inch loop with the cable (6) and slide sleeve (5) over end of cable (6).
4. Crimp sleeve (5) in place on cable (6).
5. Repeat steps 1 through 4 for other end of cable (6).

f. Installation.

1. Install dust plug (4) in inlet end of nozzle (1).
2. Install end of cable (6) on ring (3).

4-8. GROUND PLUG ASSEMBLY (See Figure 4-3).

- a. Removal. Remove screw (2) from nozzle (1).

b. Disassembly.

NOTE

If cable requires replacement, do not remove cable eye from cable.

1. Cut cable eye (5) off end of cable (4)
2. Loosen hex-head nut on ground plug (3).
3. Remove cable (4) from ground plug (3).

c. Inspection.

1. Inspect ground plug (3) for corrosion, cracks, or distortion.
2. Inspect cable (4) for corrosion, cuts, or fraying.
3. Inspect cable eye (5) for corrosion, or distortion.

- d. **Replacement.** Replace any damaged parts.

e. Reassembly.

NOTE

Plastic coating must be stripped from end of cable to ensure metal to metal contact at both ends.

1. Strip about 3/4 inch of plastic cover off each end of cable (4).

2. Insert one end of cable (4) in cable eye (5). Crimp end of cable eye (5) to cable (4).
 3. Insert other end of cable (4) in ground plug (3). Tighten hex-head nut on end of ground plug (3).
- f. **Installation.** Insert screw (2) through hole in cable eye (5). Thread screw (2) into nozzle (1) and tighten.

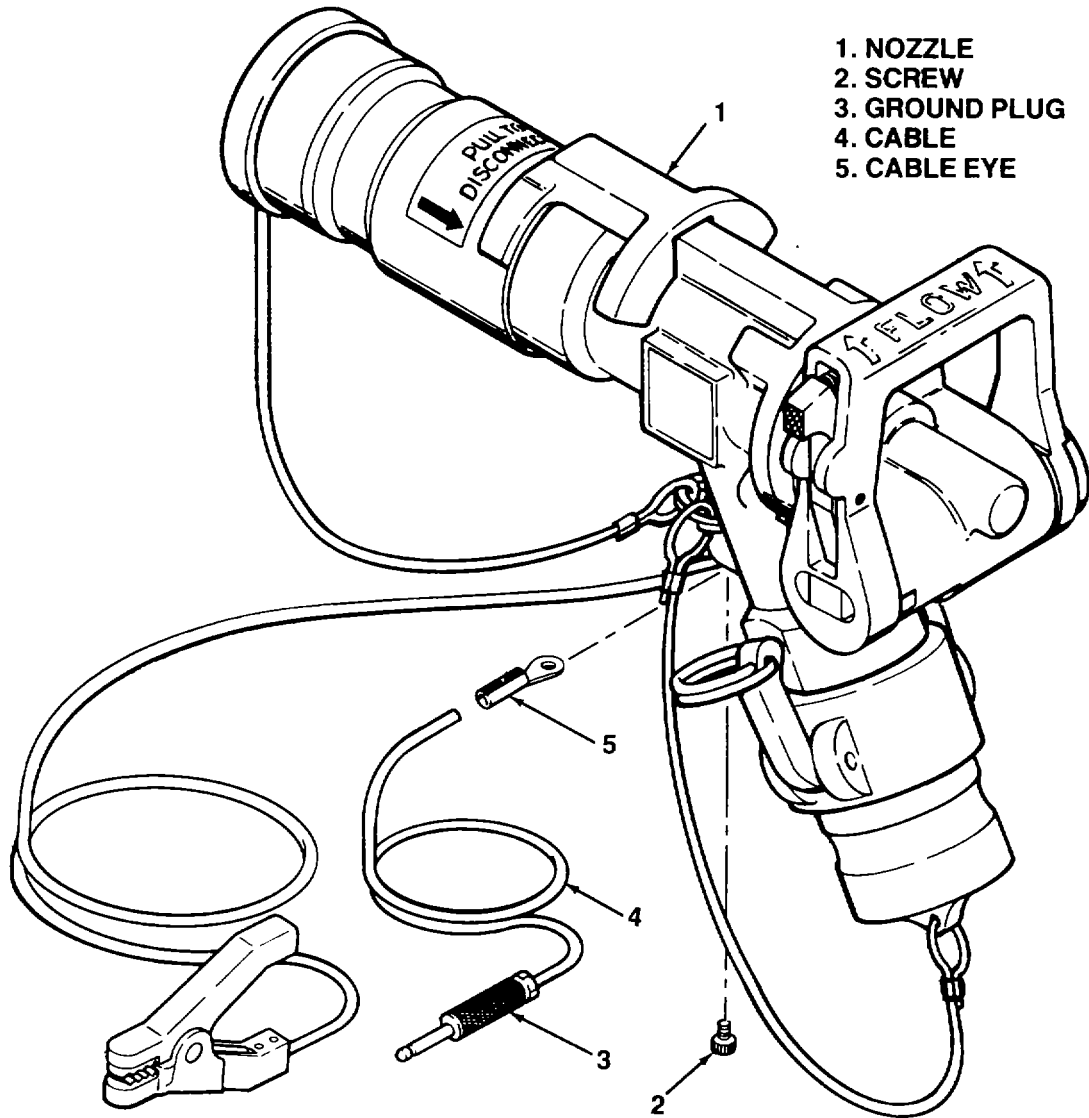

1. NOZZLE
2. SCREW
3. GROUND PLUG
4. CABLE
5. CABLE EYE

12529A

Figure 4-3. Ground Plug Assembly

4-9. GROUND CLIP ASSEMBLY (See Figure 4-4).

- a. **Removal.** Remove screw (2) from nozzle (1). Remove screw (2) from cable eye (5).
- b. **Disassembly.**

NOTE

If cable requires replacement do not remove cable eye from cable.

1. Cut cable eye (5) off end of cable (4)
2. Loosen two set-screws on ground clip (3).

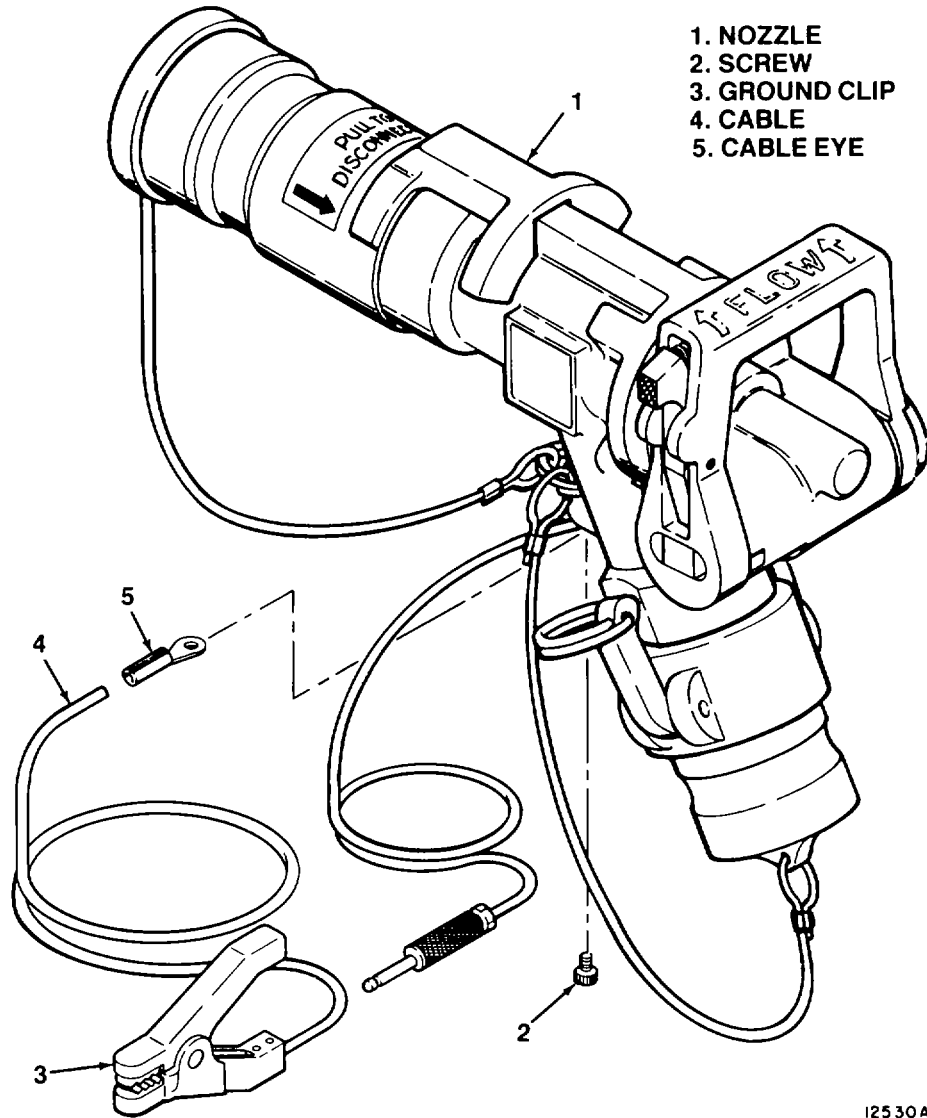

12530A

Figure 4-4. Ground Clip Assembly

3. Remove cable (4) from ground clip (3).

c. Inspection.

1. Inspect ground clip (3) for corrosion, cracks, distortion and spring tension.
2. Inspect cable (4) for corrosion, cuts, or fraying.
3. Inspect cable eye (5) for corrosion or distortion.

d. Replacement. Replace any damaged parts.

e. Reassembly.

NOTE

Plastic coating must be stripped from end of cable to ensure metal to metal contact at assembly.

1. Strip about 3/4 inch of plastic cover off each end of cable (4).
2. Insert one end of cable (4) in cable eye (5). Crimp end of cable eye (5) to cable (4).
3. Insert other end of cable (4) in ground clip (3). Tighten two set-screws on ground clip (3).

f. Installation. Insert screw (2) through hole in cable eye (5). Thread screw (2) into nozzle (1) and tighten.

4-10. CAN-LOCK COUPLING ASSEMBLY (See Figure 4-5).

a. Removal.

NOTE

Do not drop or lose gasket inside coupling.

1. Turn coupling (2) counterclockwise to remove from nozzle (1).
2. Remove o-ring (3) from coupling (2). Replace o-ring (3) if cut or distorted.

b. Installation.

1. Install o-ring (3) on threaded end of coupling (2).
2. Install coupling (2) in nozzle (1) and turn clockwise until hand tight.

4-11. UNISEX DUST CAP (See Figure 4-6).**a. Removal.**

1. Hold nozzle (1) and turn dust cap (2) counterclockwise.
2. Remove dust cap (2) from end of unisex coupling (5).
3. Remove cable (3) from ring on nozzle (1).

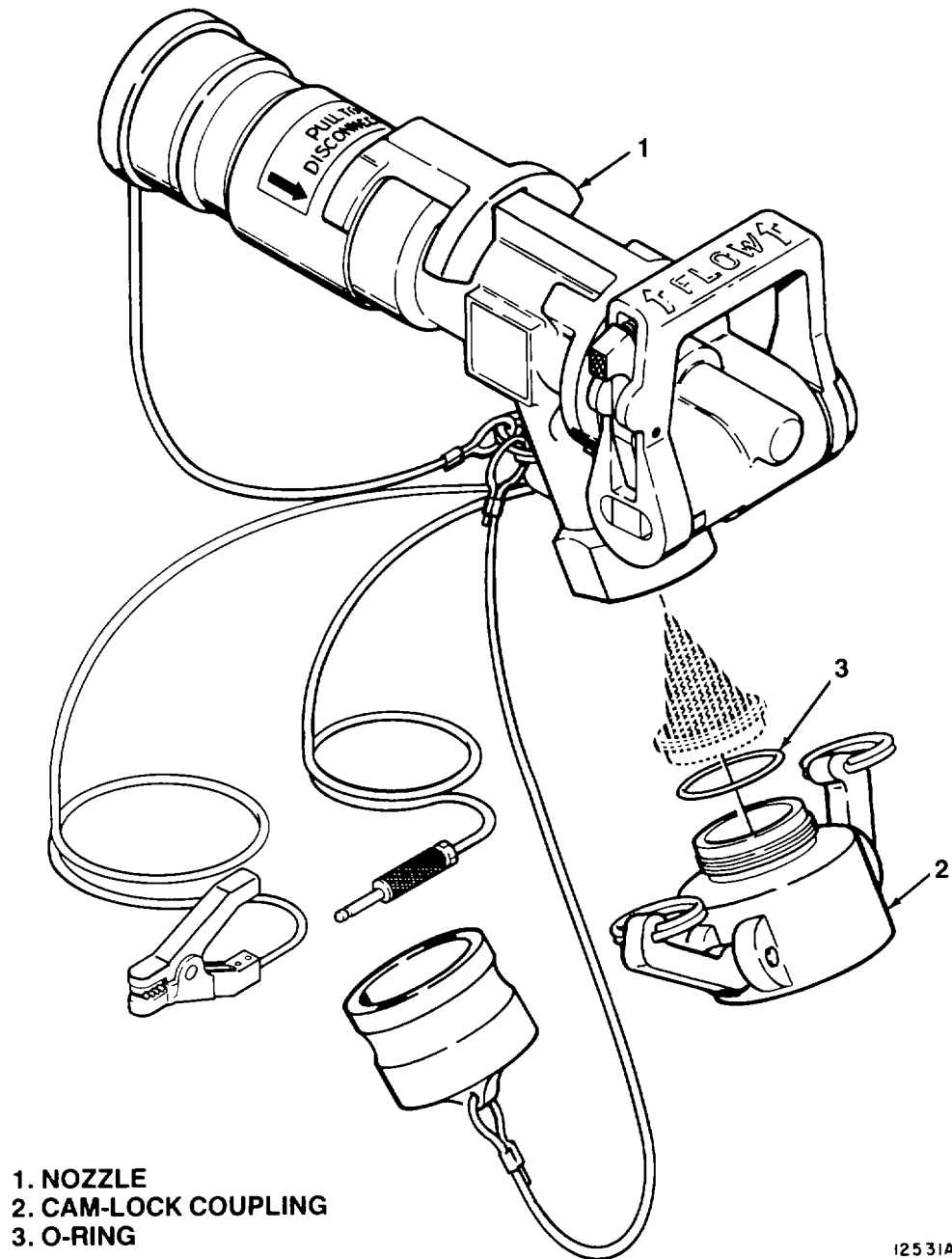

Figure 4-5. Cam-Lock Coupling Assembly

- b. **Disassembly.** Cut cable (3) at dust cap (2) and remove.

NOTE

Clean parts with a clean cloth to remove dust, dirt, fuel or grease.

- c. **Inspection.**

1. Inspect dust cap (2) for corrosion, cracks, or distortion.

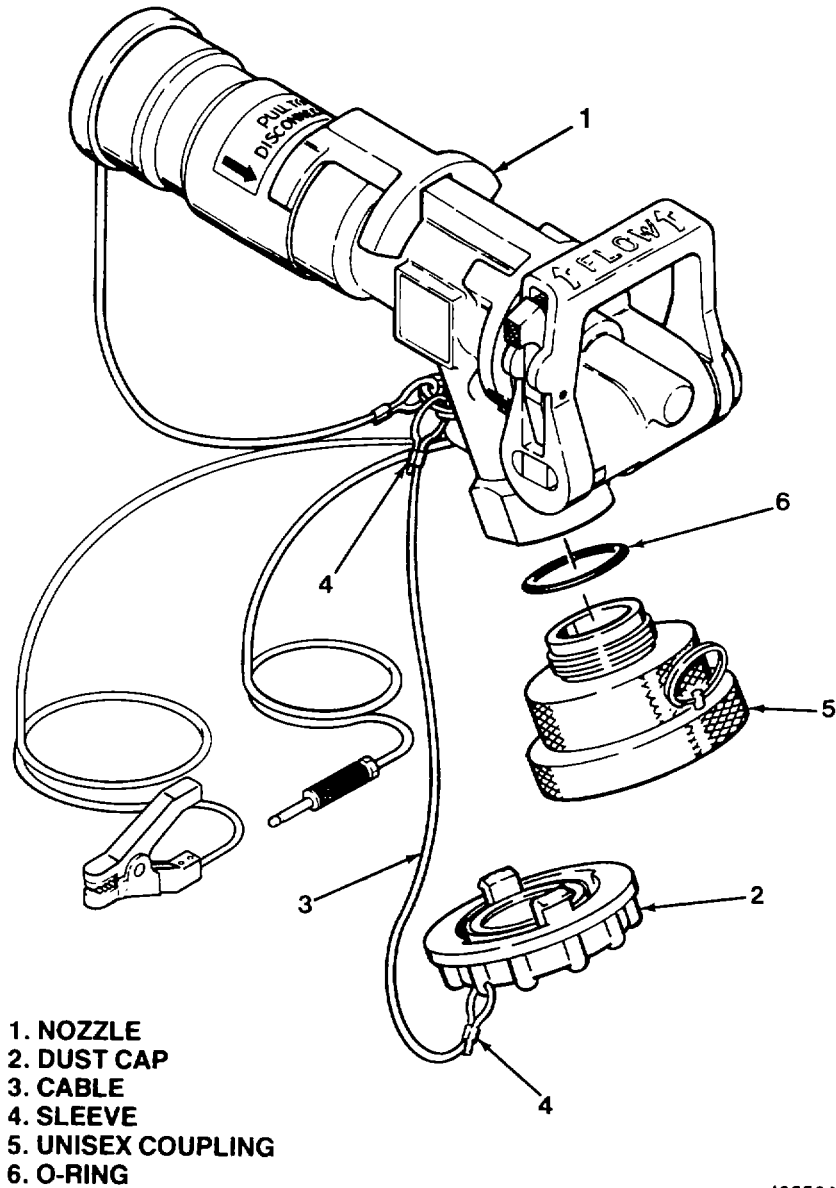

12532A

Figure 4-6. Unisex Coupling Assembly

2. Inspect cable (3) for corrosion, cracks, or fraying.

d. Replacement. Replace any damaged parts.

e. Reassembly.

1. Slide sleeve (4) down cable (3).

2. Insert one end of cable (3) through hole in dust cap (2).

3. Make a one inch loop with the cable (3) and slide sleeve (4) over end of cable (3).

4. Crimp sleeve (4) in place on cable (3).

5. If required, repeat steps 1 through 4 for other end of cable (3).

f. Installation.

1. Install dust cap (2) on end of unisex coupling (5) and turn **clockwise**.

2. Install end of cable (3) on ring of nozzle (1).

4-12. UNISEX COUPLING ASSEMBLY (See Figure 4-6).

a. Removal.

1. Turn coupling (5) counterclockwise to remove from nozzle (1).

2. Remove o-ring (6) from coupling (5). Replace o-ring (6) if cut or distorted.

b. Installation.

1. Install o-ring (6) on threaded end of coupling (5).

2. Install coupling (5) in nozzle (1) and turn clockwise until hand-tight.

Section V. PREPARATION FOR STORAGE OR SHIPMENT

4-13. ADMINISTRATIVE STORAGE

a. Placement of equipment in administrative storage should be for short periods of time when a shortage of maintenance effort exists. Items should be in mission readiness within 24 hours or within the time factors as determined by the directing authority. During the storage period appropriate maintenance records will be kept.

b. Before placing equipment in administrative storage, current maintenance services and equipment serviceable criteria (ESC) evaluations should be completed, shortcomings and deficiencies should be corrected, and all modification work orders (MWO's) should be applied.

c. Storage site selection. Inside storage is preferred for items selected for administrative storage. If inside storage is not available, trucks, vans, conex containers and other containers may be used.

4-14. PREPARATION.

1. Remove nozzle from fuel hose. Refer to paragraphs 3-4 or 3-5 for details.

NOTE

Have a suitable container available to catch any fuel spillage. Drain fuel for shipment or storage.

2. Install dust cap and dust plug in nozzle.
3. Coil ground clip and ground plug wires and secure with tape or string.
4. Inspect nozzle for dirt or other foreign material. Clean nozzle with a clean, lint-free cloth.
5. Inspect nozzle for physical damage or missing parts. Report any discrepancies to your supervisor immediately.

4-15. PACKAGING.

1. Wrap nozzle in moisture barrier paper.
2. Place nozzle in a sturdy cardboard or fiberboard container.
3. Add moisture barrier paper to container so nozzle does not move.
4. Seal container and mark the outside with the following information:
 - a. Description
 - b. Part Number
 - c. National Stock Number (listed on data plate of nozzle).
 - d. Date packaged
 - e. Serial number

Change 2 4-14

CHAPTER 5

DIRECT SUPPORT MAINTENANCE INSTRUCTIONS

Section I. TROUBLESHOOTING PROCEDURES

5-1. GENERAL.

a. This section contains troubleshooting information for locating and correcting most of the operating troubles which may develop in the nozzle. Each malfunction for an individual component is followed by a list of tests or inspections which will help to determine corrective actions to take. Perform the tests/inspections and corrective actions in the order listed.

b. This manual cannot list all malfunctions that may occur, nor all tests or inspections and corrective actions. If a malfunction is not listed or is not corrected by listed corrective actions, notify your supervisor.

5-2. TROUBLESHOOTING. Table 5-1 lists the common malfunctions which may occur during operation or maintenance of the nozzle. Perform test/inspections and corrective actions in the order listed. For nozzle disassembly/assembly procedures refer to paragraph 5-3.

Table 5-1. Troubleshooting

MALFUNCTION	TEST OR INSPECTION	CORRECTIVE ACTION
-------------	--------------------	-------------------

1. CAM-LOCK ARMS ARE LOOSE OR DO NOT LOCK IN PLACE.

Inspect cam arm and/or pin for cracks or looseness.

If damaged, replace cam arm and/or pin.

2. UNISEX COUPLING LEAKS BETWEEN BODY AND ADAPTER.

Step 1. Inspect body and adapter for cracks or damage.

If cracks or damage are found, disassemble and replace damaged parts.

Step 2. Disassemble and inspect internal o-ring for cuts or wear.

If damaged, replace internal o-ring and assemble.

Table 5-1. Troubleshooting (Cont)

MALFUNCTION	TEST OR INSPECTION	CORRECTIVE ACTION
3. INADEQUATE (SLUGGISH) FUEL FLOW.	Step 1. Remove coupling and strainer from nozzle. Check strainer for dirt or other foreign matter.	Clean strainer by removing all dirt and foreign matter.
	Step 2. While strainer is removed, inspect for any damage.	Replace strainer if damaged. Install strainer in nozzle. Install coupling and hand-tighten.
4. FLOW HANDLE WILL NOT LOCK IN FLOW (ON) OR NO FLOW (OFF) POSITION.	Step 1. Inspect thumb latch and thumb latch spring.	Check thumb latch "ear" is not cracked, rounded or broken off. Check thumb latch spring is not broken or missing. Replace either part if damaged.
	Step 2. Inspect pinion teeth position on rack.	

NOTE

This procedure can only be done during CCR Nozzle Sub-Assembly maintenance (See paragraph 5-6).

Remove snap ring, plug, washer, bushing and key from end cap. Check position of pinion teeth. As required, move one tooth and assemble parts into end cap.

5. PRESSURE OR FLOW LEAKS INTO MATING HALF WHEN HANDLE IS IN NO FLOW (OFF) POSITION.

Inspect pinion teeth position on rack.

NOTE

This procedure can only be done during CCR Nozzle Sub-Assembly maintenance (See paragraph 5-6).

Remove snap ring, plug, washer, bushing and key from end cap. Check position of pinion teeth. As required, move one tooth and assemble parts into end cap.

Table 5-1. Troubleshooting (Cont)

MALFUNCTION	TEST OR INSPECTION	CORRECTIVE ACTION
6. INDICATOR PIN DOES NOT OPERATE (DOES NOT EXTEND).	Inspect assembly of indicator pin and components for proper assembly and/or damaged parts.	<p style="text-align: center;">NOTE</p> <p>This procedure can only be done during CCR Nozzle Sub-Assembly maintenance (See paragraph 5-6).</p> <p>Remove plunger and end cap. Check components for correct position. As required, assemble in the correct position.</p>
7. LEAKAGE FROM INDICATOR PIN HOLE.	Inspect seals and pressure regulator.	<p style="text-align: center;">NOTE</p> <p>This procedure can only be done during CCR Nozzle Sub-Assembly maintenance (See paragraph 5-6).</p> <p>Disassemble nozzle and inspect seals for proper position, cuts or tears. Inspect pressure regulator for scratches or nicks. Replace all damaged parts and assemble nozzle.</p>
8. LEAKAGE BETWEEN ADAPTER AND BODY.	Inspect adapter and o-ring.	<p style="text-align: center;">NOTE</p> <p>This procedure can only be done during CCR Nozzle Sub-Assembly maintenance (See paragraph 5-6).</p> <p>Disassemble nozzle and inspect adapter for wear, cracks or distortion. Inspect o-ring for cuts or tears. Replace all damaged parts and assemble nozzle.</p>
9. LEAKAGE FROM OUTLET END OF NOZZLE WHEN CONNECTED.	Remove nozzle from receptacle. Place handle in NO FLOW (off) position. Inspect seal.	Replace seal if cut or torn.

Table 5-1. Troubleshooting (Cont)

MALFUNCTION	TEST OR INSPECTION	CORRECTIVE ACTION
10. LEAKAGE FROM OUTLET END WHILE DISCONNECTED FROM RECEPTACLE.	<p>Step 1. Look inside outlet end. See if leakage is coming from around outside of safety sleeve.</p> <p style="text-align: center;">NOTE</p> <p>This procedure can only be done during CCR Nozzle Sub-Assembly maintenance (See paragraph 5-6).</p> <p>Remove plunger and safety sleeve. Inspect position of seal (facing the correct direction). If not, remove and install seal in correct position. If seal is cut or torn, replace it. Install safety sleeve and plunger.</p> <p>Step 2. Look inside outlet end. See if leakage is coming from around plunger.</p> <p style="text-align: center;">NOTE</p> <p>This procedure can only be done during CCR Nozzle Sub-Assembly maintenance (See paragraph 5-6).</p> <p>Remove plunger and safety sleeve. Inspect parts for wear, cracks, or distortion. Replace any damaged parts. Assemble nozzle.</p>	
11. NO ELECTRICAL CONTINUITY BETWEEN GROUND CLIP/GROUND PLUG AND NOZZLE.	<p>Inspect ground cables, cap screw, and inlet coupling for dirt or corrosion.</p> <p>Remove cap screw, ground cables, and inlet coupling. Remove any dirt or corrosion from ground cables, screw, threads of inlet coupling, and body. Assemble parts and test for continuity. Replace any damaged components.</p>	
12. PULLBACK SLEEVE DOES NOT ACTIVATE OR LOCK ON TO RECEPTACLE.	<p>Disassemble nozzle and inspect parts.</p> <p style="text-align: center;">NOTE</p> <p>This procedure can only be done during CCR Nozzle Sub-Assembly maintenance (See paragraph 5-6).</p> <p>Check for cracks, distortion, out of round condition, or improper assembly of parts. Replace all damaged parts and assemble in the proper order.</p>	

Section II. MAINTENANCE PROCEDURES**WARNING**

Aviation fuel is highly flammable. No smoking or open flames are permitted in maintenance area. Failure to comply can result in injury or death to personnel.

Proper eye protection must be worn. Failure to comply can result in loss of eyesight.

5-3 GENERAL. This section consists of disassembly, inspection, replacement, cleaning, assembly, and testing of the nozzle assembly and subassemblies.

5-4. CAM-LOCK COUPLING ASSEMBLY.**a. Removal (See Figure 5-1).****NOTE**

Do not drop or lose gasket inside coupling, or strainer inside nozzle.

1. Hold nozzle (1) and pull cam arms (2) away from nozzle (1).
2. Remove dust plug (3) from coupling (4).
3. Turn coupling (4) counterclockwise to remove from nozzle (1).

b. Disassembly (See Figure 5-2).

1. Place cam-lock body (2) in a vise.
2. Drive pin out of cam arm and cam-lock body using a punch and hammer.
3. Repeat step 2 for other cam arm (1).

c. Inspection.**NOTE**

Wipe parts with a clean, lint-free cloth before inspection.

1. Inspect cam arm and pin for wear, cracks, or distortion.
2. Inspect cam-lock body (2) for wear in pin hole, cracks, or distortion.

d. Replacement. Replace any damaged parts.

e. Reassembly (See Figure 5-3).

1. Place cam-lock body on cam-lock stake plate, S1391-5, with pin hole sitting on dowel pin in cam-lock stake plate.
2. Insert cam arm between ears on cam-lock body.
3. Insert pin through ear on cam-lock body and cam arm.

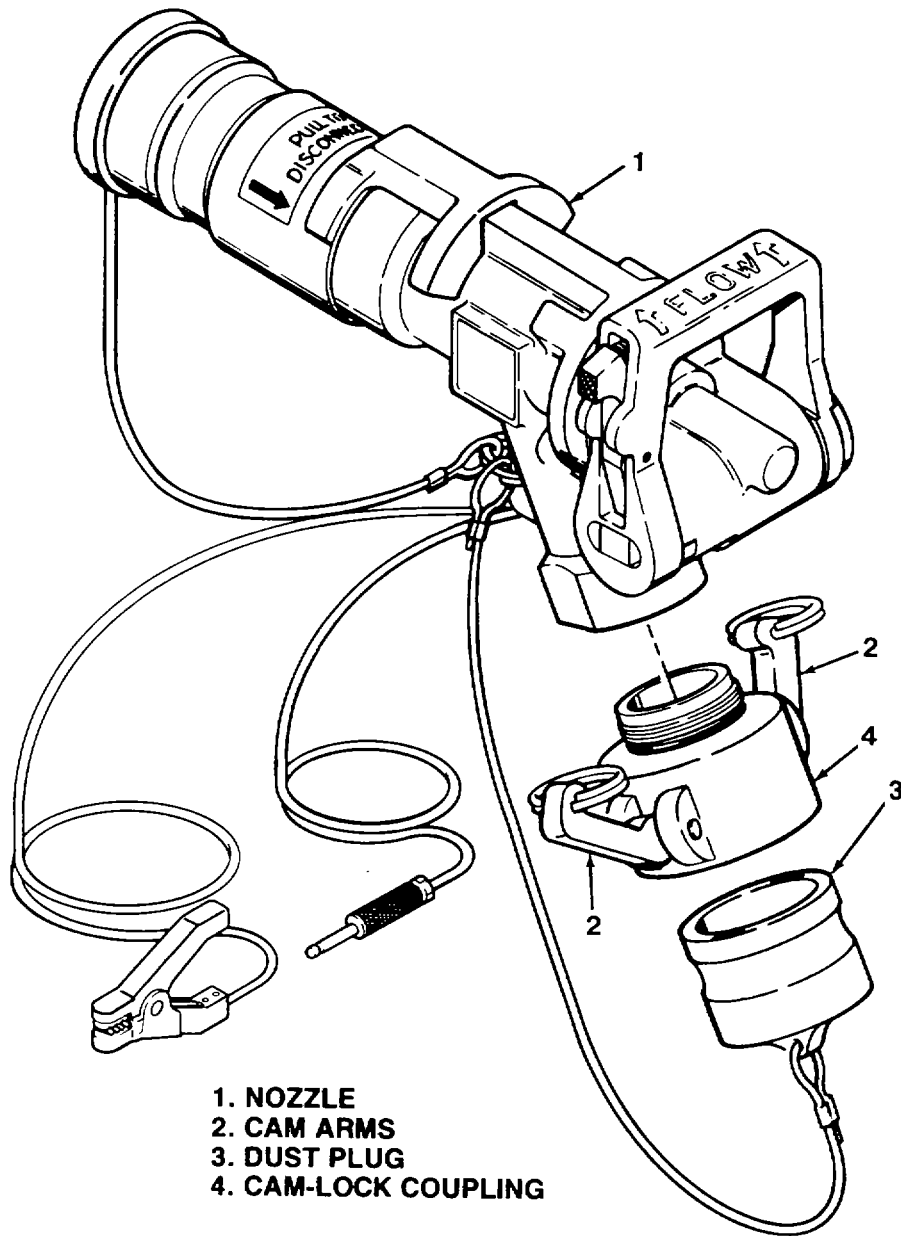

12592A

Figure 5-1. Cam-Lock Coupling Removal

NOTE

One side of pin has a recessed hole. Cam-lock stake tool goes in this hole.

4. Stake pin in cam-lock body using cam-lock stake tool, S1391-3, and hammer.
5. Remove cam-lock stake tool.
6. Turn cam-lock body to position other side on dowel pin in cam-lock stake plate, S1391-5. Repeat steps 2 thru 5.
7. Remove cam-lock body from cam-lock stake plate.

f. Installation (See Figure 5-1).

1. Install cam-lock coupling (4) in nozzle (1) and turn clockwise until hand-tight.
2. Insert dust plug (3) in end of cam-lock coupling (4).
3. Pull cam arms (2) toward nozzle (1) to lock in place.

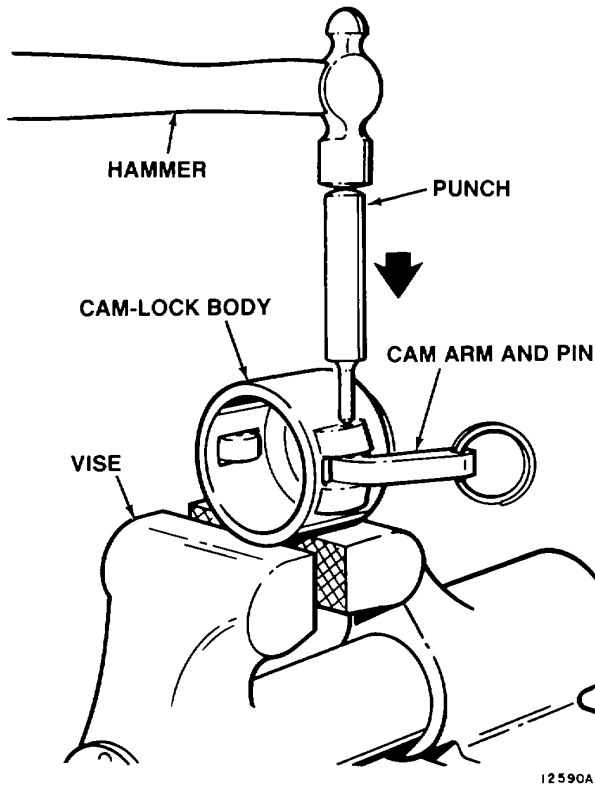

Figure 5-2. Cam Arm Disassembly

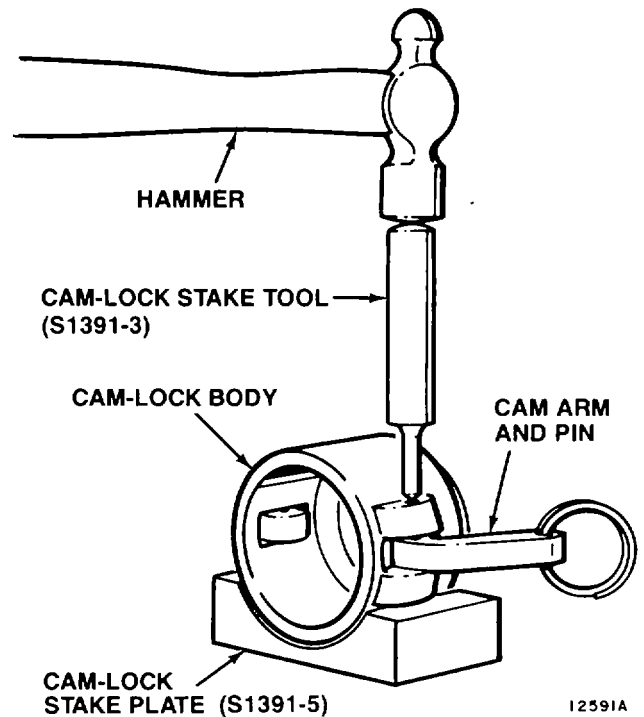
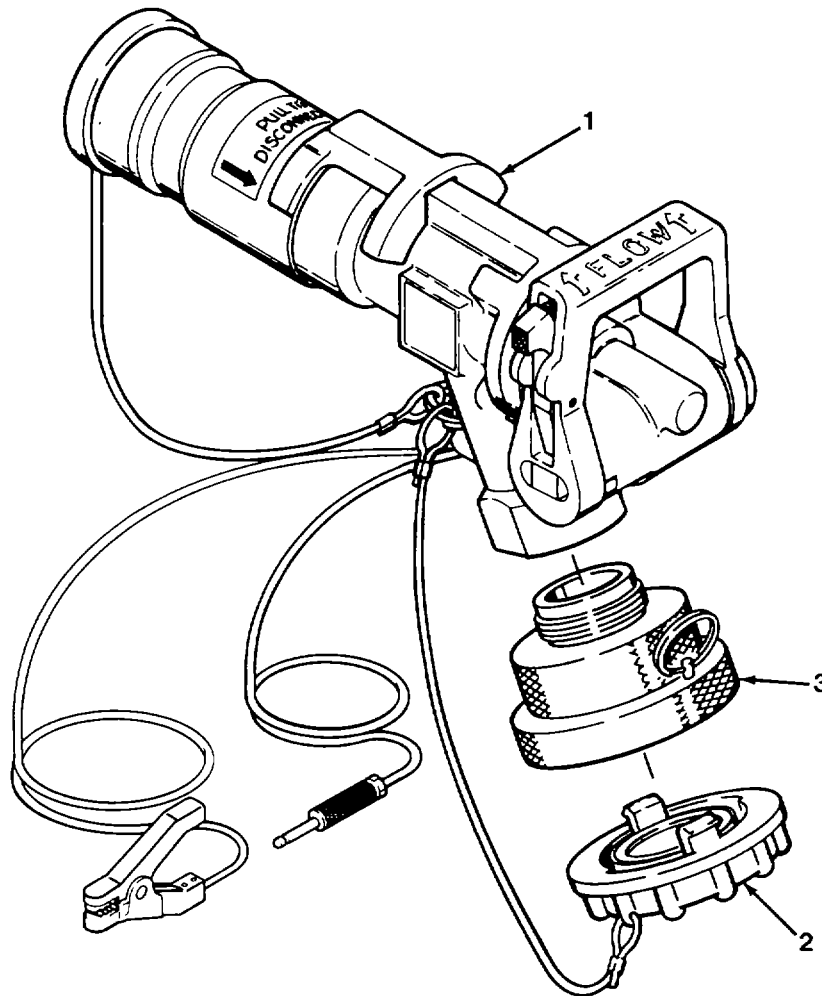

Figure 5-3. Cam Arm Assembly

5-5. UNISEX COUPLING ASSIEBLY.

a. Removal (See Figure 5-4).

1. Turn dust cap (2) counterclockwise and remove from unisex coupling (3).
2. Turn unisex coupling (3) counterclockwise and remove from nozzle (1).



- 1. NOZZLE**
- 2. DUST CAP**
- 3. UNISEX COUPLING**

12593A

Figure 5-4. Unisex Coupling Removal

b. Disassembly (See Figure 5-5).

1. Remove o-ring (1) and seal (2) from unisex coupling.
2. Remove ring (3), pin (4), and spring (5) from adapter (9).
3. Place unisex coupling in vise with wire hole facing up.
4. Remove sealant from wire hole.
5. Bend up end of wire (6). Pull wire (6) out of body (7).
6. Remove unisex coupling from vise.
7. Twist body (7) and adapter (9) in opposite directions, then pull apart.
8. Remove o-ring (8) from groove in adapter (9).

c. Inspection.**NOTE**

Wipe parts with a clean, lint-free cloth before inspection.

1. Inspect body (7) for cracks, distortion, or corrosion. Inspect grooves for corrosion and cracks.
2. Inspect adapter (9) for cracks, distortion, stripped threads, or corrosion.

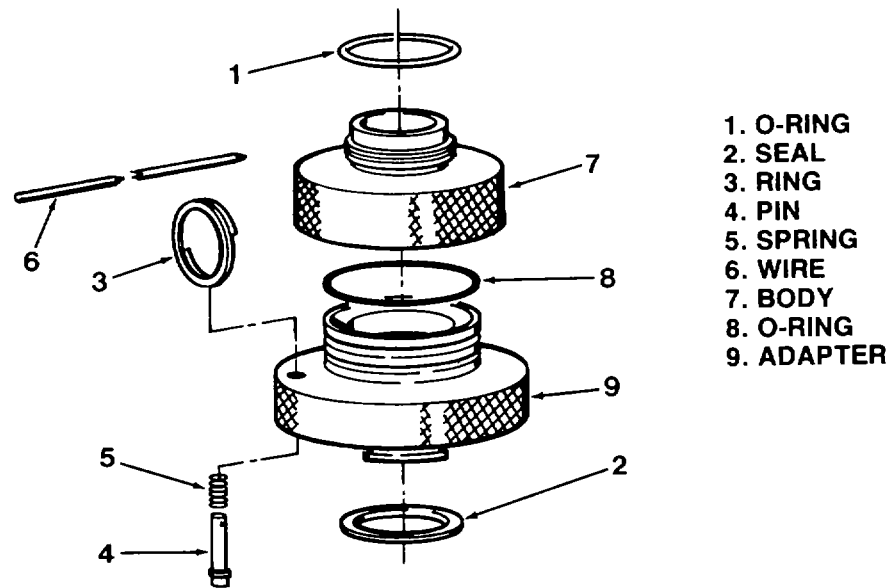

12594A

Figure 5-5. Unisex Coupling Disassembly

3. Inspect ring (3), pin (4), and spring (5) for cracks, wear, or distortion.
4. Inspect o-ring (1) and seal (2) for tears, cuts, or distortion.

d. Replacement. Replace all cracked, distorted, or heavily corroded parts. Minor corrosion can be removed with very fine emery cloth. Do not remove finish on metal.

e. Reassembly.

1. Lubricate o-ring (8) lightly with contents of grease pak supplied in repair kit. Install o-ring (8) in outer groove of adapter (9).
2. Install body (7) on adapter (9). Align wire hole in body (7) with groove in adapter (9).
3. Place body (7) and adapter (9) in vise with wire hole facing up.
4. Insert tapered end of wire (6) through wire hole and into groove of adapter (9). Drive wire (6) into adapter (9) until end drops into groove.
5. Fill wire hole with sealant (Item 1, Appendix E). Allow to dry for one-half hour.
6. Install spring (5) on end of pin (4).
7. Insert pin (4) in adapter (9) until end extends through other side. Insert ring (3) through hole in pin (4).
8. Install o-ring (1) in groove of body (7).
9. Install seal (2) in groove of adapter (9).

f. Installation (See Figure 5-4).

1. Install unisex coupling (3) in nozzle (1) and turn clockwise until hand-tight.
2. Install dust cap (2) on unisex coupling (1) and turn clockwise until hand-tight.

5-6. CCR NOZZLE SUB-ASSEMBLY.



Before disassembly, wipe the exterior of the nozzle assembly with a clean, lint-free cloth to remove dust, dirt, grease, or fuel residue. This will prevent contamination of internal parts.

a. Disassembly (See Figure 5-6).

1. Remove cap screw (1), ground clip (2), and ground plug (3) from nozzle (10).

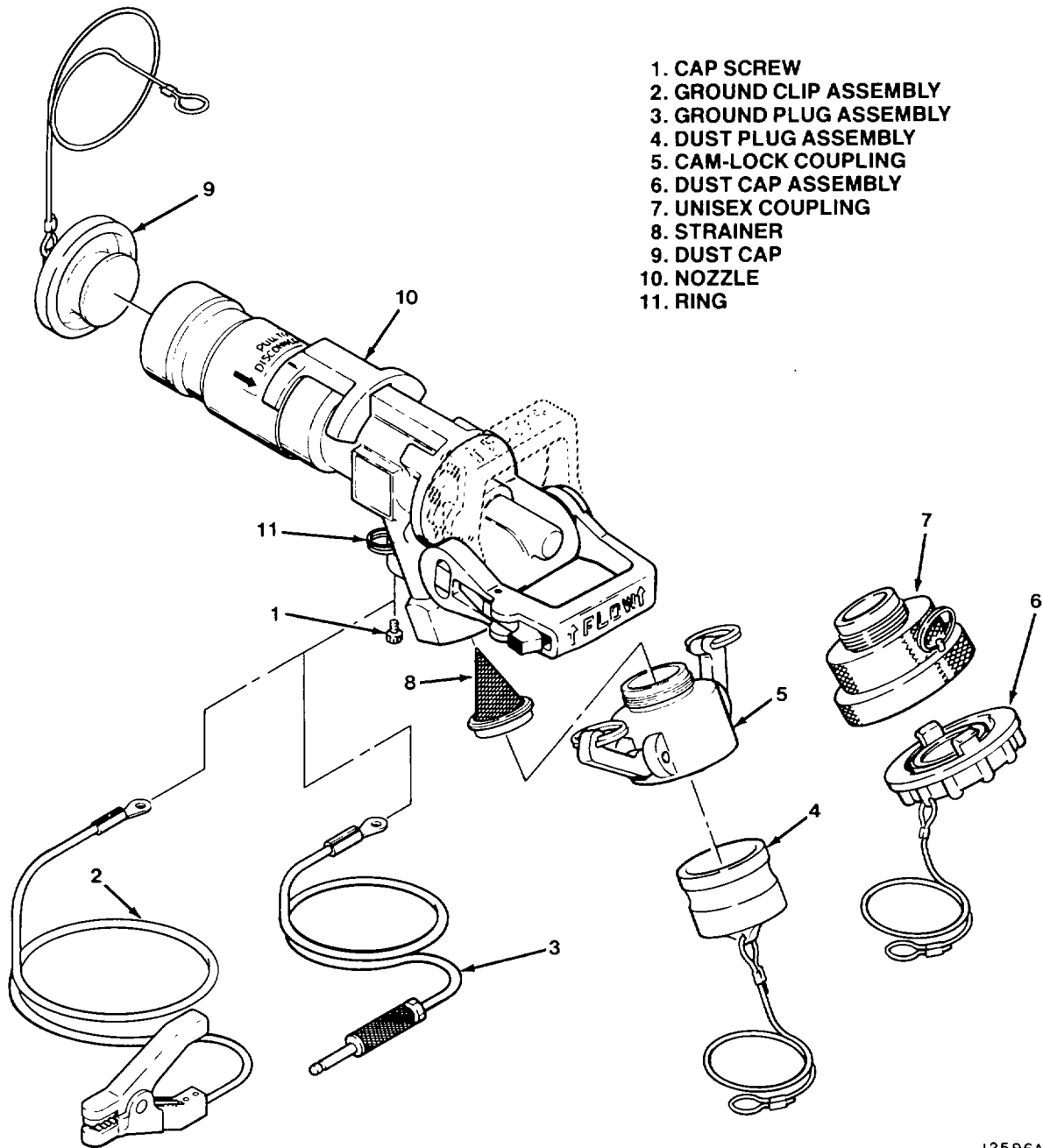

- 1. CAP SCREW
- 2. GROUND CLIP ASSEMBLY
- 3. GROUND PLUG ASSEMBLY
- 4. DUST PLUG ASSEMBLY
- 5. CAM-LOCK COUPLING
- 6. DUST CAP ASSEMBLY
- 7. UNISEX COUPLING
- 8. STRAINER
- 9. DUST CAP
- 10. NOZZLE
- 11. RING

12596A

Figure 5-6. CCR Nozzle Component Removal

2. Remove dust plug (4) or dust cap (6) from nozzle (10). Remove cable from ring (11).
3. Turn cam-lock coupling (5) or unisex coupling (7) counterclockwise and remove from nozzle (10).
4. Remove strainer (8) from inside nozzle (10).
5. Remove dust cap (9) from nozzle (10). Remove cable from ring (11). Remove ring (11) from nozzle (10).



Do not over-tighten vise. Damage to body can result.

6. Install nozzle (10) in vise with outlet end pointing up.
7. See Figure 5-7. Remove plunger (1), safety sleeve (2), and safety sleeve spring (3) from body (49) using plunger torque tool, S1391-11, and ratchet wrench. See Figure 5-8.
8. Turn body (49) in vise so handle (22) points up.
9. Remove three cap screws (4 and 5) and end cap (6) from body (49).
10. Remove bonded guide (7) from back of end cap (6). Remove o-ring (8) and check valve (9) from bonded guide (7).
11. Depress thumb latch (26) and push handle (22) toward piston (14). Pull rack (10) and piston (14) out of end cap (6).
12. Remove piston return spring (11) from rack (10).
13. Remove o-ring (12) from piston (14).
- 14.



Do not remove spring pin from rack and piston unless inspection shows part replacement is required. Damage to piston can result.

14. If required, remove spring pin (13) from rack (10) and piston (14). Pull rack (10) out of piston (14).
15. Clamp handle (22) in vise with thumb latch (26) pointing down.

NOTE

Flow control pin may drop out after parts are removed.

16. Remove retaining ring (15), plug (16), compression washer (17), bushings (18), pinion (19), and key (20) from inside end cap (6).
17. Remove flow control pin (21) from bottom of handle (22).

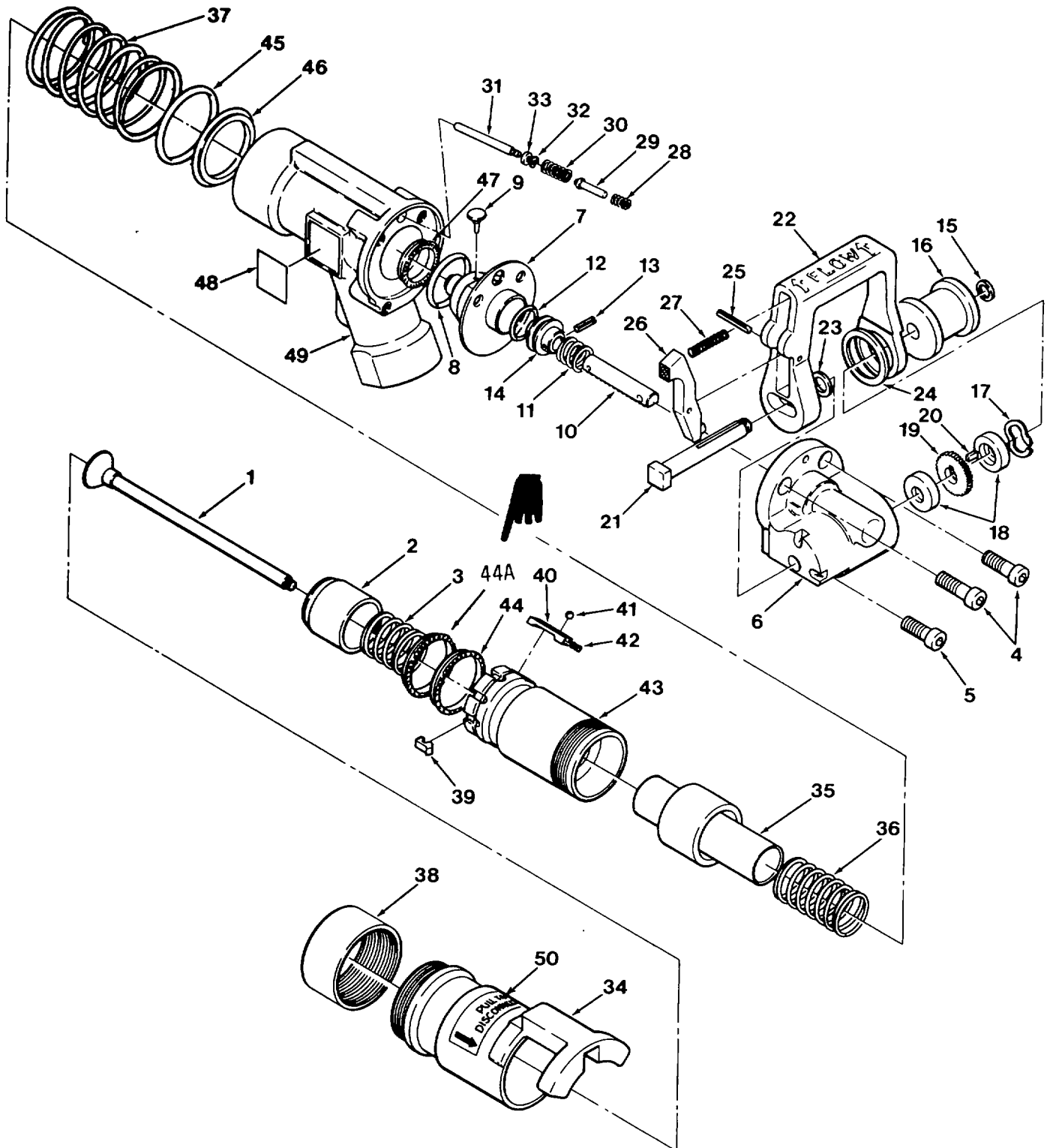

125588

Figure 5-7. CCR Nozzle Disassembly

Change 3 5-13

LEGEND FOR FIGURE 5-7. NOZZLE DISASSEMBLY

- | | | |
|--------------------------|-----------------------------|-------------------------------|
| 1. PLUNGER | 18. BUSHING | 35. PRESSURE REGULATOR SLEEVE |
| 2. SAFETY SLEEVE | 19. PINION | 36. PRESSURE REGULATOR |
| 3. SAFETY SLEEVE SPRING | 20. KEY | 37. PULLBACK SLEEVE SPRING |
| 4. CAP SCREW | 21. FLOW CONTROL PINSRING | 38. NOSE SLEEVE |
| 5. CAP SCREW | 22. HANDLE | 39. LATCH |
| 6. END CAP | 23. NON-METALLIC WASHER | 40. RELEASE PIN |
| 7. BONDED GUIDE | 24. WASHER | 41. BALL BEARING |
| 8. O-RING | 25. SPRING PIN | 42. RELEASE PIN SPRING |
| 9. CHECK VALVE | 26. THUMB LATCH | 43. ADAPTER |
| 10. RACK | 27. LATCH SPRING | 44. ADAPTER SEAL |
| 11. PISTON RETURN SPRING | 28. INDICATOR RETURN SPRING | 44A. SEAL VACUUM RELEASE |
| 12. O-RING | 29. INDICATOR PIN | 45. O-RING |
| 13. SPRING PIN | 30. SAFETY SPRING | 46. PRESSURE REGULATOR SEAL |
| 14. PISTON | 31. INDICATOR SHAFT | 47. PRESSURE REGULATOR SEAL |
| 15. RETAINING RING | 32. RETAINING RING | 48. I. D. LABEL |
| 16. PLUG | 33. INDICATOR BUSHING | 49. BODY |
| 17. COMPRESSION WASHER | 34. PULLBACK SLEEVE | 50. DECAL |

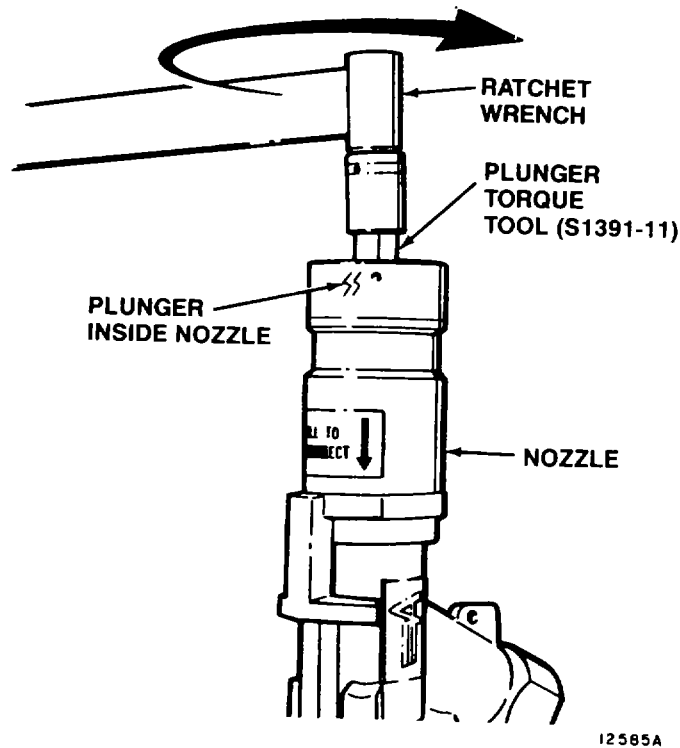

Figure 5-8. Plunger Removal

18. Remove end cap (6) and washers (23 and 24) from handle (22). Remove handle (22) from vise.

CAUTION

Do not remove spring pin from handle and thumb latch unless inspection shows replacement is required. Damage to handle can result.

19. If required, remove spring pin (25) from handle (22) and thumb latch (26).
20. Remove thumb latch (26) and latch spring (27) from handle (22).
21. Remove indicator return spring (28), indicator pin (29), safety spring (30), and indicator shaft (31) from body (49).

NOTE

Do not remove parts from indicator shaft unless inspection shows replacement is required.

22. If required, remove retaining ring (32) and indicator bushing (33) from indicator shaft (31).
23. Turn body (49) and clamp in vise with outlet end pointing up.
24. Remove nose sleeve (38) from pullback sleeve (34) using torque spanner tool, S1391-12, and ratchet wrench. See Figure 5-9.

NOTE

Latches will tend to drop out.

25. Remove six latches (39) from adapter (43).
26. Remove pullback sleeve (34) from body (49) by depressing release pins (40).
27. Remove two release pins (40), ball bearings (41), release pin springs (42) and pullback sleeve spring (37) from end of adapter (43).
28. Remove adapter (43) from body (49) using adapter torque tool, S1391-7, and ratchet wrench. See Figure 5-10.
29. Remove vacuum release seal (44A) and adapter seal (44) from inside adapter (43).
30. Remove pressure regulator sleeve (35), and pressure regulator spring (36) from body (49).
31. Remove o-ring (45) and pressure regulator seals (46 and 47) from inside body (49).

Change 3 5-15

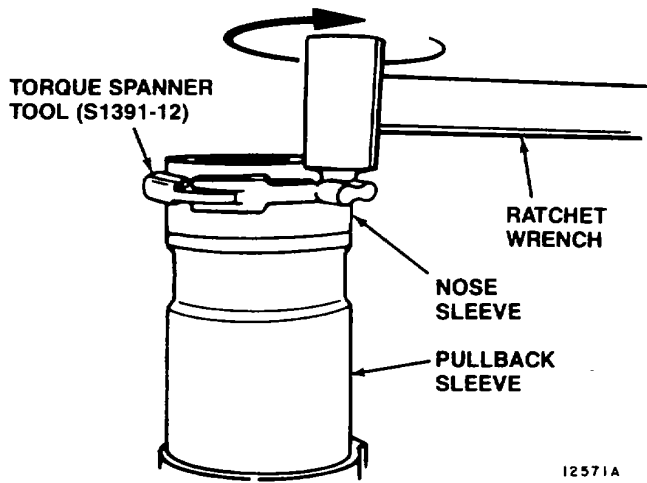

Figure 5-9. Nose Sleeve Removal

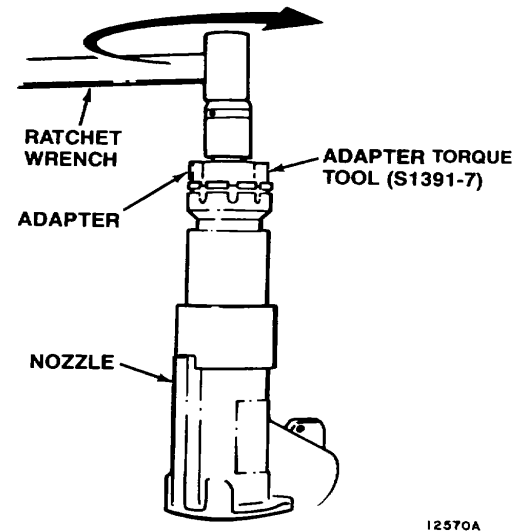

Figure 5-10. Adapter Removal

NOTE

Do not remove label or decal unless replacement is required.

b. Cleaning.



Do not use wire brushes or wire wheels to clean parts. Failure to comply can result in damage to metal finish of parts.

1. Wipe metal parts with a clean, lint-free cloth to remove fuel, dust or other foreign material.
2. Remove heavy deposits of dirt or grease with a soft bristled brush dipped in cleaning solvent (Item 2, Appendix E). Use low pressure, filtered air to dry parts.
3. As required, flush body (49) with cleaning solvent (Item 2, Appendix E) to remove fuel and foreign material from internal passages. Use low pressure, filtered air to dry body (49).

c. Inspection.

1. Inspect piston (14), rack (10), and spring pin (13) as follows.
 - (a) Piston (14) must not have any nicks or scratches in o-ring groove or around outer edge. Metal finish must not be damaged.
 - (b) Spring pin (13) must be below flush on both sides of piston (14), and not be loose in hole.
 - (c) Rack (10) teeth must not be chipped, cracked, or broken.
2. Inspect handle (22), thumb latch (26), and spring pin (25) as follows.
 - (a) Handle (22) must not have any cracks, or distortion in shape. Hole for plug (16) must be free of dirt or corrosion.
 - (b) Spring pin (25) must be below flush on both sides of handle (22), and must not be loose in hole.
 - (c) Thumb latch (26) must move freely when pressed. Ear at bottom must not be cracked or broken.
3. Inspect plunger (1) for straightness, nicks, burrs or distortion of slot in head. Metal finish of shaft must not be worn through. Threads must not show any signs of stripping or cross-threading.
4. Inspect flow control pin (21) for straightness, cracks, and corrosion. Keyway and groove for retaining ring (15) must have no nicks, burrs or distortion. Corners of head must not be broken off or rounded.
5. Inspect indicator pin (29) and indicator shaft (31) for straightness, corrosion, and wear of metal finish. Groove for retaining ring (32) on indicator shaft (31) must not have any nicks or burrs.
6. Inspect body (49) as follows.
 - (a) Check external surfaces for cracks, corrosion or wear of metal finish.
 - (b) Check internal surfaces for scoring, scratches, nicks or burrs in grooves for seals (46 and 47) or o-ring (45).
 - (c) Check internal passages for dirt or any residue of cleaning solvent.
 - (d) Check threaded holes for cross-threading, dirt, or corrosion.
7. Inspect all springs for cracks, or distortion of shape. Check springs per Table 5-2.

Table 5-2. Spring Dimensions

DESCRIPTION	PART NUMBER	LENGTH (INCHES)		DIAMETER (INCHES)	
		FREE	COMPRESSED	INSIDE DIAMETER	OUTSIDE DIAMETER
Safety Sleeve Spring	AE10488-445	6.33	0.920	1.32	1.50
Piston Return Spring	AE10488-450	1.68	0.36	0.80	0.95
Pressure Regulator Spring	AE10488-447	4.69	0.83	1.24	1.43
Pullback Sleeve Spring	AE10488-446	5.16	0.60	2.45	2.65
Release Pin Spring	AE10488-451	0.49	0.20	0.14	0.18
Latch Spring	AE10488-453	1.70	0.60	0.19	0.25
Safety Spring	AE10488-448	0.50	0.210	0.30	0.37
Indicator Return Spring	AE10488-449	0.50	0.11	0.22	0.26

8. Inspect all other metal parts as follows .

(a) Check for cracks, distortion, corrosion, or wear of finish.

(b) Check seal and o-ring grooves for nicks, scratches, or burrs that could damage seals and o-rings during assembly.

(c) Check threads for stripping, nicks, cross-threading, or corrosion.

d. Replacement.

1. Replace all cracked, distorted, or heavily corroded parts.
2. Minor corrosion can be removed with very fine emery cloth. Do not remove finish on metal.
3. Small nick's or burrs can be removed with fine emery cloth. Do not change shape or size of grooves or threads.
4. Replace any decal or label that cannot be read.

e. Reassembly (See Figure 5-7).

CAUTION

The nozzle must be assembled in the order shown using the special tools indicated. Failure to do so can result in faulty operation of nozzle.

NOTE

A major overhaul kit is available for the nozzle. The kit contains all necessary seals, o-rings, small metal parts, and a grease pak for lubricating seals and o-rings.

1. Lightly lubricate adapter seal (44) and vacuum release seal (44A).
2. Install adapter seal and vacuum release seal in adapter, ensuring the ridges in the vacuum seal are positioned to the open end of the nozzle and the web of the adapter seal faces the threaded end of the adapter.

NOTE

Be sure to seat both seals completely into the grooves without kinks or wrinkles.

3. Insert release pin spring (42) in slot at back of release pin (40).
4. Insert release pin (40) in groove of adapter (43) with release pin spring (42) compressed against shoulder of adapter (43). Install ball bearing (41) in hole of release pin (40).
5. Hold release pin (40), release pin spring (42), and ball bearing (41) against adapter (43). Turn adapter (43) and install second set of parts in opposite groove of adapter (43).
6. Hold parts and slide adapter (43) into release pin mechanism tool, S1391-8. About 1/2 inch of adapter (43) should extend beyond end of tool. See Figure 5-11.

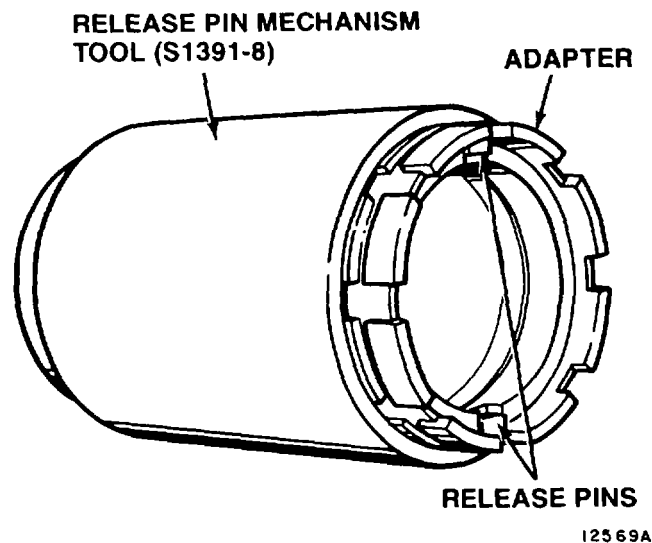

Figure 5-11. Adapter Assembly

7. Slide adapter (43) and release pin mechanism tool, S1391-8, inside pullback sleeve (34). End of adapter (43) should extend beyond end of pullback sleeve (34).
8. Hold end of adapter (43) and pull release pin mechanism tool, S1391-8, out of pullback sleeve (34). See Figure 5-12.
9. Insert six latches (39) in slots of adapter (43). Thread nose sleeve (38) onto pullback sleeve (34) until handtight.
10. Lightly lubricate pressure regulator seals (46 and 47), and o-ring (45).
11. Install small pressure regulator seal (47) in groove at back of body (49). Webbed side must face toward handle end.
12. Install large pressure regulator seal (46) in second groove from outlet end of body (49). Webbed side must face outlet end.
13. Install o-ring (45) in outlet end of body (49).
14. Install body (49) in vise jaws, S1391-15, and clamp in vise. See Figure 5-13.
15. Insert pressure regulator spring (36) in pressure regulator sleeve (35). Install both parts inside body (49).
16. Install regulating positioning tool, S1391-9, in body (49) as follows. See Figure 5-14.

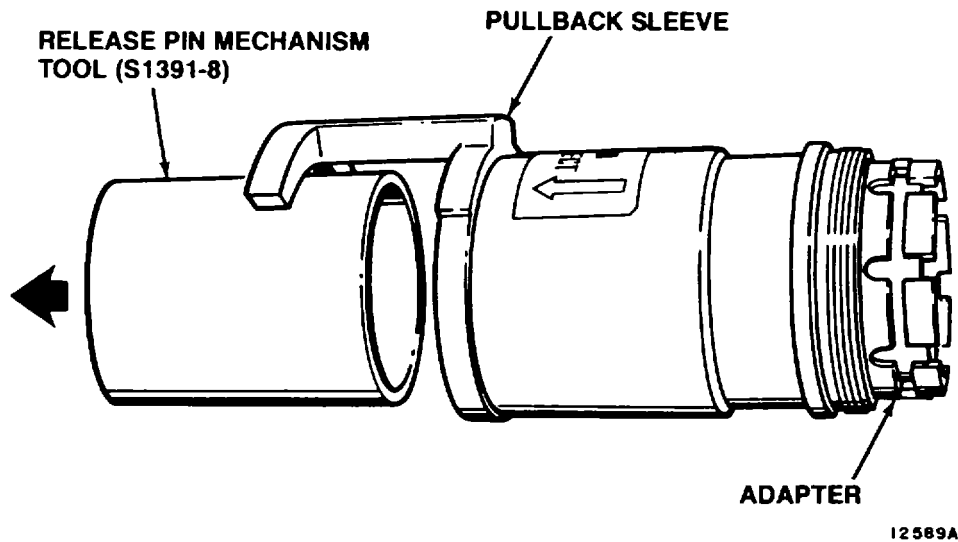

Figure 5-12. Removal of Release Pin Mechanism Tool

- (a) Remove large locating nut from end of threaded rod.
 - (b) Push down on pressure regulator sleeve (35) until it passes pressure regulator seals (46 and 47).
 - (c) Slide threaded rod through pressure regulator sleeve (35) until end extends out the bottom of body (49).
 - (d) Thread locating nut on end of threaded rod and hand-tighten until pressure regulator (35) has 1/4 inch of travel. See Figure 5-14.
16. Install pullback sleeve spring (37) in pullback sleeve (34).
 17. Install pullback sleeve (34) and adapter (43) on body (49). Push down on pullback sleeve (34).
 18. Thread adapter (43) into body (49) using adapter torque tool, S1391-7, and a torque wrench. Tighten to a torque of 40-50 ft-lbs. See Figure 5-15. Remove adapter torque tool.
 19. Remove large locating nut from end of threaded rod. Remove regulating positioning tool, S1391-9, from body (49).

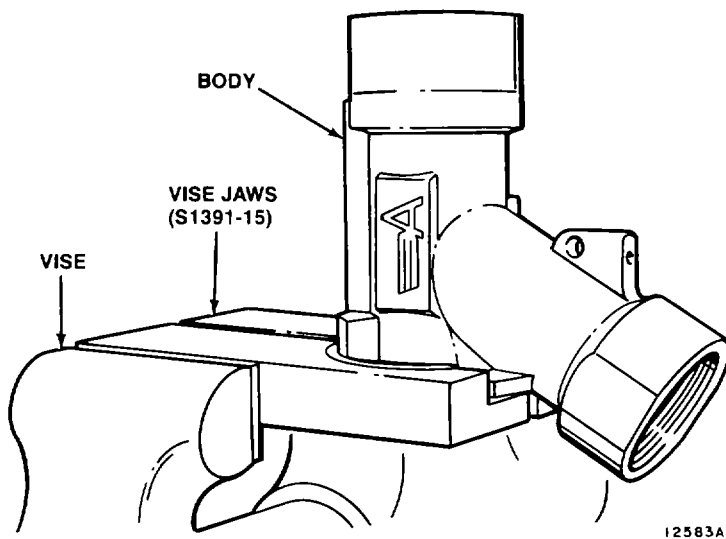

Figure 5-13. Body Installation.

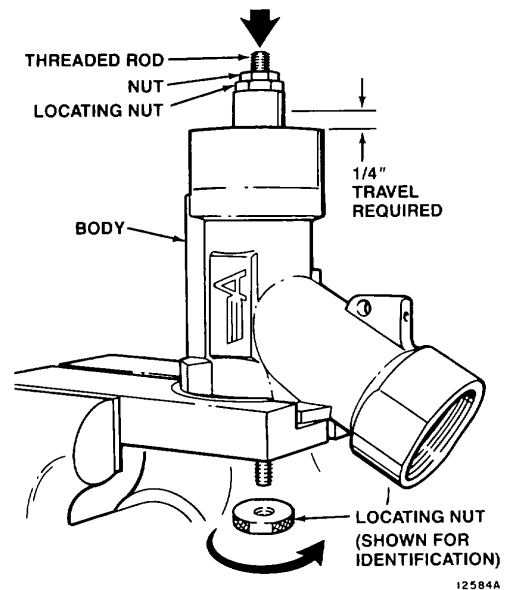

Figure 5-14. Tool Installation

20. Tighten nose sleeve (38) to a torque of 20-30 ft-lbs using torque spanner tool, S1391-12, and a torque wrench. See Figure 5-16.

21. Remove body (49), from vise. Remove vise jaws, S1391-15, from body (49). Install body (49) in vise with nose sleeve (38) pointing down.

22. If required, assemble piston (14) to rack (10) as follows. See Figure 5-17.

(a) Slide rack (10) into piston (14) and align pin hole.

(b) Place rack (10) and piston (14) in pin stake plate, S1391-6.

(c) Insert spring pin (13) in hole of piston (14). Drive spring pin (13) into position using pin stake tool, S1391-4, and hammer.

(d) Remove pin stake tool. Remove rack (10) and piston (14) from pin stake plate.

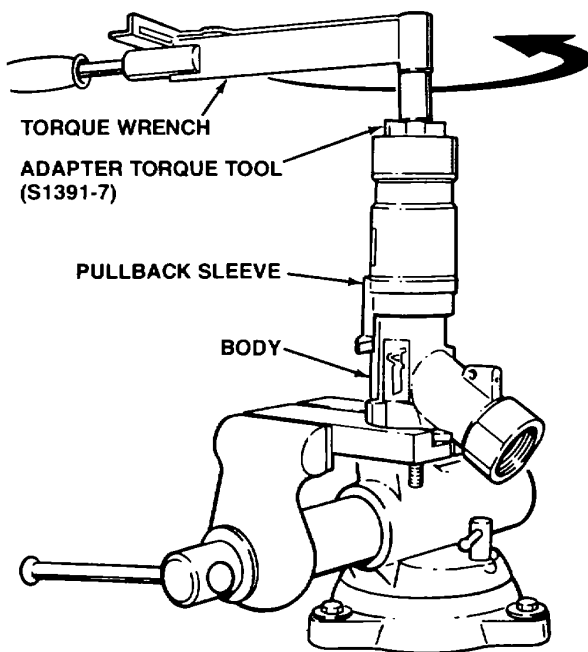

I2579A

Figure 5-15. Adapter Installation

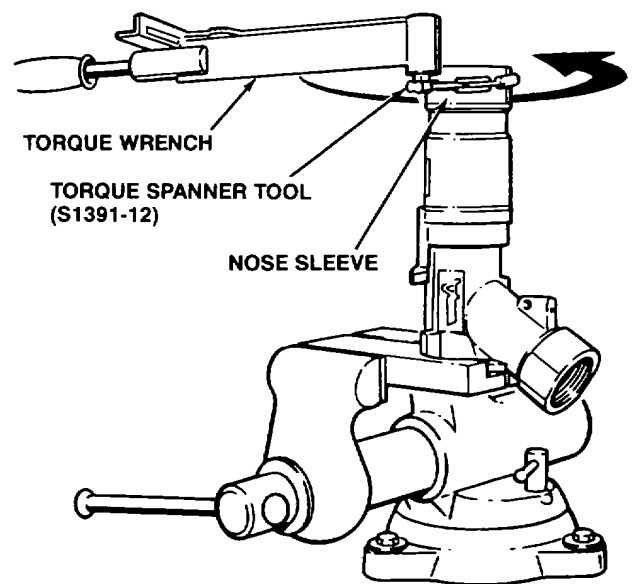

I2580A

Figure 5-16. Torqueing Nose Sleeve

(e) Check spring pin (13). It must be flush on both sides of piston (14).

23. If required, assemble thumb latch (26) to handle (22) as follows. See Figure 5-18.

(a) Place handle (22) on a flat surface.

(b) Insert thumb latch (26) in side of handle (22) and align holes.

(c) Insert spring pin (25) in handle (22). Drive spring pin (25) through handle (22) and thumb latch (26) using pin stake tool, S1391-4, and hammer.

(d) Remove pin stake tool. Check spring pin (25). It must be flush with surface of handle (22).

(e) Pivot thumb latch (26) away from handle (22). Install latch spring (27) in thumb latch (26) and hole in handle (22).

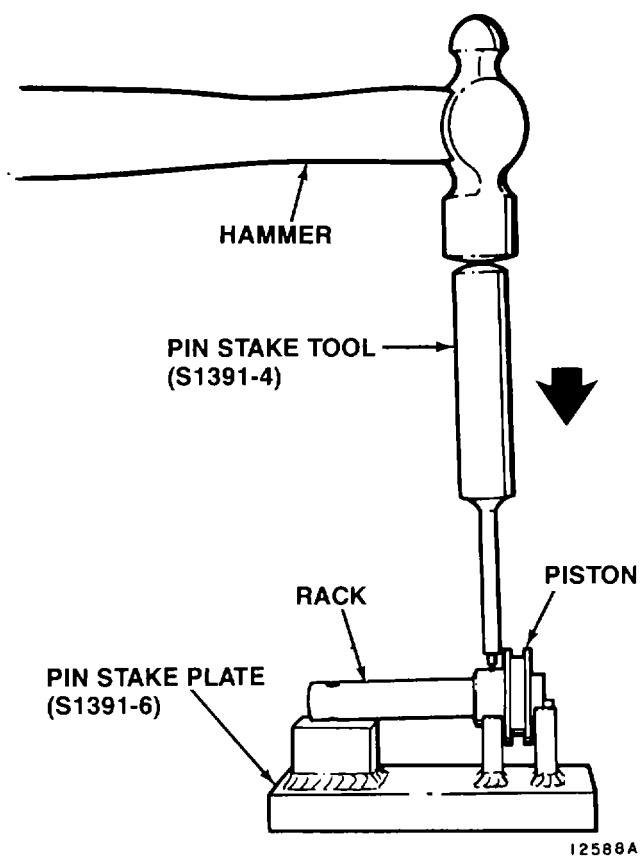

Figure 5-17. Piston and Rack Assembly

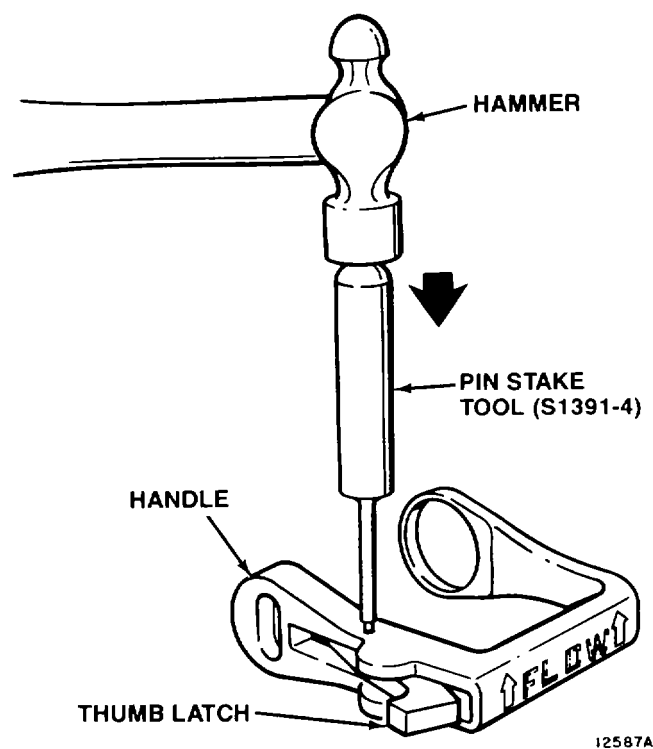

Figure 5-18. Handle and Thumb Latch Assembly

24. Lightly lubricate o-ring (12). Install in groove of piston (14).
25. Lightly lubricate o-ring (8). Install in groove of bonded guide (7).
26. Lightly lubricate check valve (9). Insert pointed end through hole in bonded guide (7). Use a pair of needle nose pliers inside bonded guide to pull on pointed end of check valve (9) until it snaps in place.
27. Install piston (14) in bonded guide (7). Push on rack (10) until piston (14) stops in bonded guide (7).
28. Install bonded guide (7) in body (49) with rack (10) pointing up. Three holes in bonded guide (7) must be aligned with three holes in body (49).
29. Remove body (49) from vise. Insert a metal rod through hole in rack (10) and clamp metal rod in vise. See Figure 5-19. Nose sleeve (38) on body (49) should point up.
30. Install safety sleeve spring (3) in safety sleeve (2). Insert plunger (1) through safety sleeve (2). Install parts in body (49).

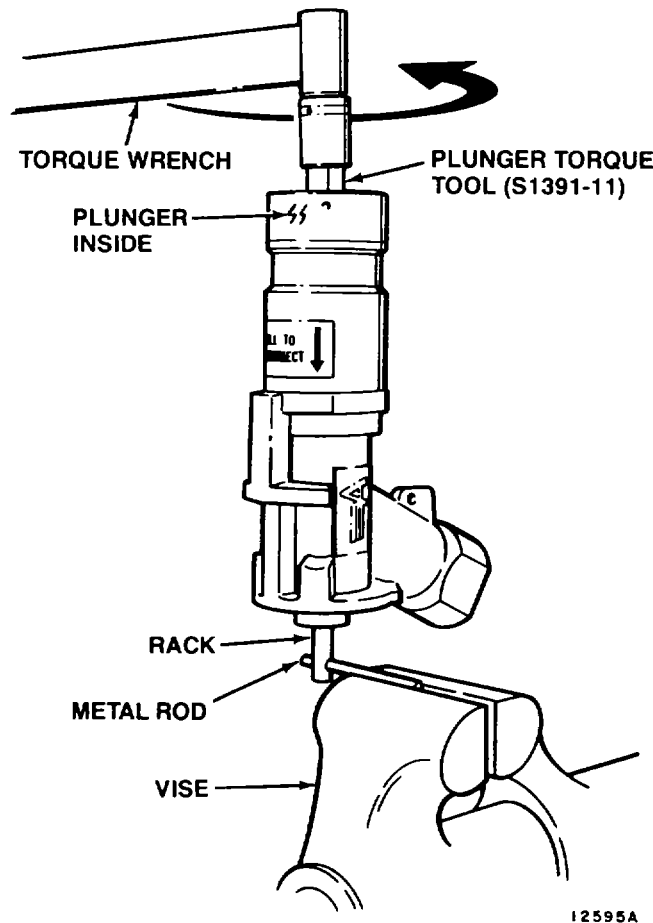

Figure 5-19. Plunger Assembly

31. Press down to compress safety sleeve spring (3) and hand-thread plunger (1) into bonded guide (7). Tighten plunger (1) to a torque of 5-7 ft-lbs. using plunger torque tool, S1391-11, and torque wrench. See Figure 5-19.

32. Remove body (49) from vise and metal rod from rack (10). Place body (49) in vise with nose sleeve (38) pointing down.

33. Turn rack (10) clockwise until teeth point away from three holes in bonded guide (7) and toward inlet end of body (49). Insert piston return spring (11) over rack (10) and into bonded guide (7).

34. If removed, assemble indicator bushing (33) and retaining ring (32) on end of indicator shaft (31). Install indicator shaft (31) in body (49).

35. Install safety spring (30) on top on indicator shaft (31).

36. Install indicator return spring (28) on shaft of indicator pin (29).

Insert both parts in body (49) on top of safety spring (30).

37. Install end cap (6) on body (49) and align screw holes.

38. Install three cap screws (4 and 5) through end cap (6) and into body (49). Tighten in a criss-cross pattern to a torque of 15-17 ft-lbs. Remove body (49) from vise.

39. Install handle (22), non-metallic washer (23), and washer (24), on end cap (6). Handle (22) must be in FLOW (on) position.

40. Insert flow control pin (21) through handle (22) and into end cap (6).

Keyway must face thumb latch (26).

41. Install rack positioning tool, S1391-10, in outlet end of body (49). See Figure 5-20.

42. Install pin positioning block, S1391-13, on top of flow control pin (21).

See Figure 5-21.

43. Hold pin positioning block, S1391-13, against flow control pin (21) and turn body (49) over.

44. Lay body (49) on workbench with flow control pin (21) and pin positioning block facing down.

45. Install one bushing (18) and pinion (19) in handle (22). Keyway in pinion (19) must line up with keyway in flow control pin (21). The tooth above pinion keyway must mesh with second full valley on rack (10). See Figure 5-22.

46. Install key (20) in keyways of rack (10) and pinion (19). Install other bushing (18), compression washer (17), and plug (16) on top of pinion (19).

47. Install retaining ring (15) using expansion tool, S1391-14, as follows. See Figure 5-23.

(a) Install cone in handle (22).

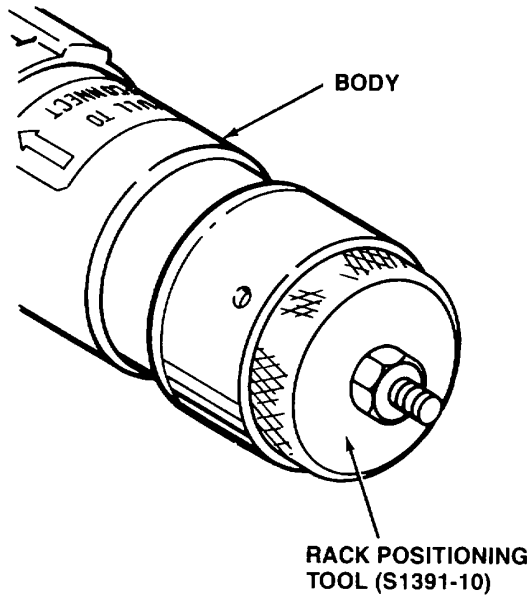

12578A

Figure 5-20. Rack Positioning Tool

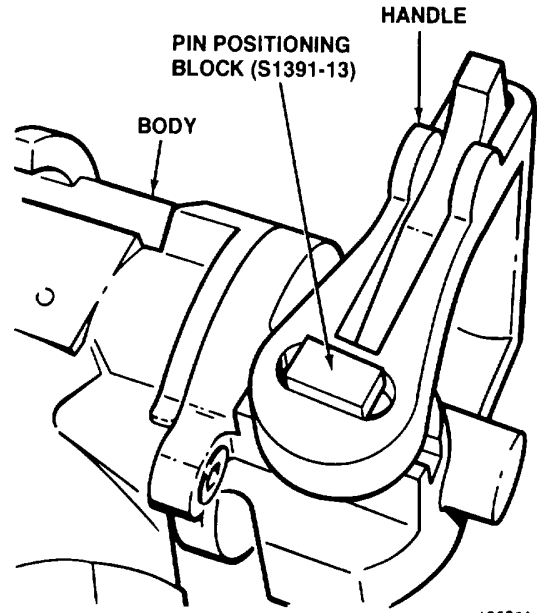

12586A

Figure 5-21. Pin Positioning Tool

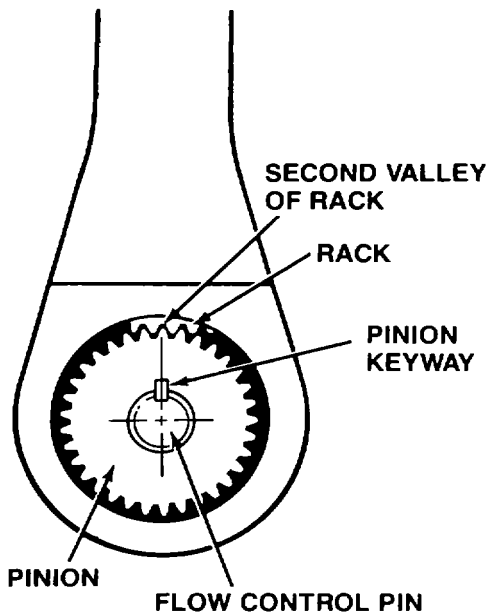

12581A

Figure 5-22. Pinion Assembly

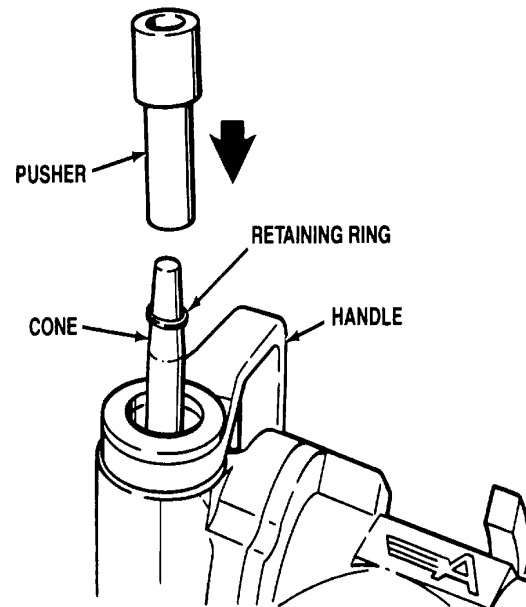

12582A

Figure 5-23. Ring Assembly

- (b) Install retaining ring (15) on end of cone.
 - (c) Install pusher over end of cone. Push down until retaining ring (15) snaps into groove of flow control pin (21).
 - (d) Remove pusher and cone from handle (22).
48. Remove pin positioning block, S1391-13, from body (49).
 49. Remove rack positioning tool, S1391-10, from outlet end of body (49).
 50. If removed, install new I.D. label (48) on side of body (49) using adhesive (Item 3, Appendix E).

NOTE

For nozzle assembly, model AE83206R, use label 23052-3. For nozzle assembly, model AE83501R, use label 23052-4.

51. If removed, install new decal (50) on pullback sleeve (34).
52. Check handle operation as follows.
 - (a) Press thumb latch (26).
 - (b) Move handle (22) from FLOW (on) to NO FLOW (off) position.
 - (c) Release thumb latch (26).

NOTE

With thumb latch released handle must lock in flow or no flow positions.

- (d) Handle (22) must move without sticking or binding. If it does not, disassemble handle components and check for proper assembly. Repeat disassembly step 16 and assembly steps 41 through 49 above.
- (e) Thumb latch (26) must engage in notches of end cap (6) and must lock handle (22) in position. If it does not, check locking ear on thumb latch (26). If it is broken, replace thumb latch (26).

53. Check operation of pullback sleeve (34) and latches (39) as follows.
 - (a) Depress release pins (40). Pull pullback sleeve (34) towards handle (22). It must move freely without binding. If it does not, disassemble nozzle and check parts for correct order of assembly.
 - (b) With pullback sleeve (34) pulled toward handle (22), all six latches (39) must pivot without binding. If they do not, check latches (39) and adapter (43) for damage.

54. Install strainer (8) in nozzle (10). See Figure 5-6.
55. Install cam-lock coupling (5) or unisex coupling (7) on nozzle (10). Hand-tighten only.



Failure of any test is cause for rejection of nozzle assembly until fault is corrected.

- f. Testing. After repair and prior to release for aircraft refueling, test nozzle in an operating, pressurized refueling system to ensure no leakage occurs.

All data on pages 5-29 and 5-30, including Figure 5-24, have been deleted.

Change 4 5-28

APPENDIX A

REFERENCES

A-1. SCOPE. This appendix lists all forms, field manuals, technical publications and miscellaneous publications referenced in this manual.

A-2. FORMS.

Equipment Daily or Monthly Log.....	DA Form 2408-1
Equipment Inspection and Maintenance Work Sheet	DA Form 2404
Maintenance Request	DA Form 2407
Quality Deficiency Report.....	SF 368
Recommended Changes to DA Publications and Blank Forms.....	DA Form 2028-2
Uncorrected Fault Record	DA Form 2408-14
Component Removal and Repair/Overhaul Record.....	DA Form 2410
Aircraft Component Historical Record.....	DA Form 2408-16

A-3. TECHNICAL MANUALS.

Procedures For Destruction of Army Equipment to Prevent Enemy Use	TM 750-244-3
---	--------------

A-4. MISCELLANEOUS PUBLICATIONS.

The Army Maintenance Management System (TAMMS).....	DA PAM 738-750
Expendable/Durable Items	CTA 50-970
Classification, Reclassification, Maintenance, Issuance and Reporting of Maintenance Training Aircraft.....	AR 700-42

APPENDIX B

MAINTENANCE ALLOCATION CHART

Section I. INTRODUCTION

B-1. GENERAL.

a. This section provides a general explanation of all maintenance and repair functions authorized at various maintenance categories.

b. The Maintenance Allocation Chart (MAC) in section II designates overall authority and responsibility for the performance of maintenance functions on the identified end item or component. The application of the maintenance functions to the end item or component will be consistent with the capacities and capabilities of the designated maintenance categories.

c. Section III lists the tools and test equipment (both special tools and common tool sets) required for each maintenance function as referenced from section II.

d. Section IV contains supplemental instructions and explanatory notes for a particular maintenance function.

B-2. MAINTENANCE FUNCTIONS. Maintenance functions will be limited to and defined as follows:

a. Inspect. To determine the serviceability of an item by comparing its physical, mechanical, and/or electrical characteristics with established standards through examination (e.g. by sight, sound, or feel).

b. Test. To verify serviceability by measuring the mechanical, pneumatic, hydraulic, or electrical characteristics of an item and comparing those characteristics with prescribed standards.

c. Service. Operations required periodically to keep an item in proper operating condition, i.e., to clean (includes decontaminate, when required), to preserve, to drain, to paint, or to replenish fuel, lubricants, chemical fluids, or gases.

d. Adjust. To maintain or regulate, within prescribed limits, by bringing into proper or exact position, or by setting the operating characteristics to specified parameters.

e. Aline. To adjust specified variable elements of an item to bring about optimum or desired performance.

f. Calibrate. To determine and cause corrections to be made or to be adjusted on instruments or test, measuring, and diagnostic equipments used in precision measurement. Consists of comparisons of two instruments, one of which is a certified standard of known accuracy, to detect and adjust any discrepancy in the accuracy of the instrument being compared.

g. Remove/Install. To remove and install the same item when required to perform service or other maintenance functions. Install may be the act of emplacing, seating, or fixing into position a spare, repair part, or module (component or assembly) in a manner to allow the proper functioning of an equipment or system.

h. Replace. To remove an unserviceable item and install a serviceable counterpart in its place. "Replace" is authorized by the MAC and is shown as the 3rd position code of the SMR code.

i. Repair. The application of maintenance services, including fault location/troubleshooting, removal/installation, and disassembly/assembly procedures, and maintenance actions to identify troubles and restore serviceability to an item by correcting specific damage, fault, malfunction, or failure in a part, subassembly, module (component or assembly), end item, or system.

j. Overhaul. That maintenance effort (service/action) prescribed to restore an item to a completely serviceable/operational condition as required by maintenance standards in appropriate technical publications (i.e. DMWR). Overhaul is normally the highest degree of maintenance performed by the Army. Overhaul does not normally return an item to like new condition.

k. Rebuild. Consists of those services/actions necessary for the restoration of unserviceable equipment to a like new condition in accordance with original manufacturing standards. Rebuild is the highest degree of materiel maintenance applied to Army equipment. The rebuild operation includes the act of returning to zero those age measurements (hours/miles, etc.) considered in classifying Army equipment/components.

B-3. EXPLANATION OF COLUMNS IN THE MAC, SECTION II.

a. Column (1) - Group Number. Column 1 lists functional group code numbers, the purpose of which is to identify maintenance significant components, assemblies, subassemblies, and modules with the next higher assembly. End item group number shall be "01".

b. Column (2) - Component/Assembly. Column 2 contains the names of components, assemblies, subassemblies, and modules for which maintenance is authorized.

Column (3) - Maintenance Function. Column 3 lists the functions to be performed on the item listed in Column 2. (For detailed explanation of these functions, see paragraph B-2.)

d. Column (4) - Maintenance Category. Column 4 specifies, by the listing of a work time figure in the appropriate subcolumn(s), the category of maintenance authorized to perform the function listed in Column 3. This figure represents the active time required to perform the maintenance function at the indicated category of maintenance. If the number or complexity of the tasks within the listed maintenance function vary at different maintenance categories, appropriate work time figures will be shown for each category. The work time figure represents the average time required to restore an item (assembly, subassembly, component, module, end item, or system) to a serviceable condition under typical

field operating conditions. This time includes preparation time (including any necessary disassembly/assembly time), troubleshooting/fault isolation time, and quality assurance/ quality control time in addition to the time required to perform the specific tasks identified for the maintenance functions authorized in the maintenance allocation chart. The symbol designations for the various maintenance categories are as follows:

C.....	Operator or Crew
O.....	Organizational Maintenance
F.....	Direct Support Maintenance
H.....	General Support Maintenance
L.....	Specialized Repair Activity (SRA)
D.....	Depot Maintenance

e. Column (5) Tools and Equipment. Column 5 specifies, by code, those common tool sets (not individual tools), and special tools, TMDE, and support equipment required to perform the designated function.

f. Column (6) Remarks. This column shall, when applicable, contain a letter code, in alphabetic order, which shall be keyed to the remarks contained in Section IV.

B-4. EXPLANATION OF COLUMNS IN TOOL AND TEST EQUIPMENT REQUIREMENTS, SECTION III.

a. Column (1) Reference Code. The tool and test equipment reference code correlates with a code used in the MAC, Section II, Column 5.

b. Column (2) Maintenance Category. The lowest category of maintenance authorized to use the tool or test equipment.

c. Column (3) Nomenclature. Name or identification of the tool or test equipment.

d. Column (4) National Stock Number. The National stock number of the tool or test equipment.

e. Column (5) - Tool Number. The manufacturer's part number.

B-5. EXPLANATION OF COLUMNS IN REMARKS, SECTION IV.

a. Column (1) - Reference Code. The code recorded in column 6, Section II.

b. Column (2) Remarks. This column lists information pertinent to the maintenance function being performed as indicated in the MAC, Section II.

Section II. MAINTENANCE ALLOCATION CHART FOR CCR NOZZLE ASSEMBLY

(1) GROUP NUMBER	(2) COMPONENT ASSEMBLY	(3) MAINTENANCE FUNCTION	(4) MAINTENANCE LEVEL					(5) TOOLS AND EQUIPMENT	(6) REMARKS
			C	O	F	H	D		
01	Nozzle Assembly	Inspect	0.1						
		Repair			1.0			1 thru 17A	
		Replace			1.0				
		Overhaul			2.0			1 thru 17	A,B,C
0101	Cap Assembly	Inspect	0.1						
		Replace		0.1					A
0102	Ground Clip Assembly	Inspect	0.1						
		Test		0.1					A,C
		Repair		0.1					A,C
0103	Coupling or Adapter Assembly	Inspect	0.1						
		Repair			0.2			9,10	A
		Replace		0.1					
0104	Plug or Cap Assembly	Inspect	0.1						
		Repair			0.2				A
		Replace		0.1					A
0105	Ground Plug Assembly	Inspect	0.1						
		Test		0.1					A,C
		Repair			0.2				A,C
		Replace		0.1					A
0106	Nozzle Sub- Assembly	Inspect	0.1						
		Test			1.0				A,C
		Repair			1.0			1 thru 8, 11 thru 17	A,C
		Replace			1.0				
		Overhaul			2.0			1 thru 8, 11 thru 17	A,B,C

Section III. TOOL AND TEST EQUIPMENT REQUIREMENTS FOR CCR NOZZLE ASSEMBLY

(1) REFERENCE CODE	(2) MAINTENANCE CATEGORY	(3) NOMENCLATURE	(4) NATIONAL STOCK NUMBER	(5) TOOL NUMBER
1		Deleted		
2		Deleted		
3	F	Jaw, Vise		S1391-15
4	F	Tool, Mechanical, Pin, Release		S1391-8
5	F	Tool, Positioning, S 1391-9 Regulator		
6	F	Tool, Expansion		S1391-14
7	F	Tool, Stake, Pin		S1391-4
8	F	Plate, Stake, Pin		S1391-6
9	F	Tool, Stake, Camlock		S391-3
10	F	Plate, Stake, Camlock		S1391-5
11	F	Block, Positioning, Pin		S1391-13
12	F	Tool, Torque, Spanner		S1391-12
13	F	Tool, Torque, Plunger		S1391-11
14	F	Tool, Torque, Adapter		S1391-7
15	F	Pkg, Preformed, O-ring		MS29513-134
16	F	Tool, Positioning, Rack		S1391-10
17	F	Cam-lock Assembly		AE83932R

Section IV. REMARKS

- A - Requires common tools from automotive shop set.
- B - Requires major repair kit, p/n AE20074-053
- C - Multimeter required

APPENDIX C

COMPONENTS OF END ITEM/BASIC ISSUE ITEMS

Section I. INTRODUCTION

C-1. SCOPE. This appendix lists components of end item and basic issue items for the CCR Nozzle Assembly to help you inventory items required for safe and efficient operation.

C-2. GENERAL. The Components of End Item/Basic Issue Items List is divided into the following sections:

a. Section II. Components of End Item. This listing is for informational purposes only, and is not authority to requisition replacements. These items are part of the end item, but are removed and separately packaged for transportation or shipment. As part of the end item, these items must be with the end item whenever it is issued or transferred between property accounts. Illustrations are furnished to assist you in identifying the items.

b. Section III. Basic Issue Items. These are the minimum essential items required to place the CCR Nozzle Assembly in operation, to operate it, and to perform emergency repairs. Although shipped separately packaged, BII must be with the CCR Nozzle Assembly during operation and whenever it is transferred between property accounts. The illustrations will assist you with hard-to-identify items. This manual is your authority to request/requisition replacement BII, based on TOE/MTOE authorization of the end item.

C-3. EXPLANATION OF COLUMNS. The following provides an explanation of columns found in the tabular listings:

a. Column (1) - Illustration Number (Illus Number). This column indicates the number of the illustration in which the item is shown.

b. Column (2) - National Stock Number. Indicates the National Stock Number assigned to the item and will be used for requisitioning purposes.

c. Column (3) - Description. Indicates the Federal item name and, if required, a minimum description to identify and locate the item. The last line for each item indicates the FSCM (in parentheses) followed by the part number.

d. Column (4) - Unit of Measure (U/M). Indicates the measure used in performing the actual operational/maintenance function. This measure is expressed by a two-character alphabetical abbreviation (e.g. ea, in, pr).

e. Column (5) - Quantity required (Qty rqr). Indicates the quantity of the item authorized to be used with/on the equipment.

Section II. COMPONENTS OF END ITEM

(1) ILLUS NUMBER	(2) NATIONAL STOCK NUMBER	(3) DESCRIPTION, (FSCM) AND PART NUMBER	USABLE ON CODE	(4) U/M	(5) QTY RQD
------------------------	---------------------------------	---	-------------------	------------	-------------------

There are no Components of End Item for the CCR Nozzle.

Section III. BASIC ISSUE ITEMS

(1) ILLUS NUMBER	(2) NATIONAL STOCK NUMBER	(3) DESCRIPTION, (FSCM) AND PART NUMBER	USABLE ON CODE	(4) U/M	(5) QTY RQD
1	N/A	Technical Manual TM 5-4930-234-13&P	EAL, EBV	EA	1

APPENDIX D

ADDITIONAL AUTHORIZATION LIST

Section I. INTRODUCTION

- D-1. **SCOPE.** This appendix lists additional items you are authorized for the support of the CCR Nozzle Assembly.
- D-2. **GENERAL.** This list identifies items that do not have to accompany the CCR Nozzle Assembly and that do not have to be turned in with it. These items are all authorized to you by CTA, MTOE, TDA, or JTA.
- D-3. **EXPLANATION OF LISTING.**

a. National stock numbers, descriptions, and quantities are provided to help you identify and request the additional items you require to support this equipment. The items are listed in alphabetical sequence by item name under the type document (i.e., CTA, MTOE, TDA, or JTA) which authorizes the item to you.

b. If the item you require differs between serial numbers of the same model, effective serial numbers are shown in the last line of the description. If item required differs for different models of this equipment, the model is shown under the "Useable on code" heading in the description column.

Section II. ADDITIONAL AUTHORIZATION LIST

(1) NATIONAL STOCK NUMBER	(2) DESCRIPTION FSCM AND PART NUMBER	USABLE ON CODE	(3) U/M Auth	(4) QTY
---------------------------------	--	-------------------	--------------------	------------

There are no additional authorized items for use with the CCR Nozzle Assembly.

APPENDIX E

EXPENDABLE/DURABLE SUPPLIES AND MATERIALS LIST

Section 1. INTRODUCTION

E-1. SCOPE. This appendix lists expendable/durable supplies and materials needed to operate and maintain the CCR Nozzle Assembly. These items are authorized by CTA 50-970, Expendable Items (Except Medical, Class V, Repair Parts and Heraldic Items).

E-2. EXPLANATION OF COLUMNS.

a. Column (1) - Item number. This number is assigned to the entry in the listing and is referenced in the narrative instructions to identify the material (e.g., "Use cleaning compound, Item 5, Appendix C").

b. Column (2) - Level. This column identifies the lowest level of maintenance that requires the listed item. These are as follows:

- C - Operator/Crew
- 0 - Organizational Maintenance
- F - Direct Support Maintenance
- H - General Support Maintenance
- D - Depot Maintenance

c. Column (3) - National Stock Number. This is the National stock number assigned to the item; use it to request or requisition the item.

d. Column (4) - Description. Indicates the Federal item name and, if required, a description to identify the item. The last line for each item indicates the Federal Supply Code for Manufacturer (FSCM) in parentheses followed by the part number.

e. Column (5) - Unit of Measure (U/HM). Indicates the measure used in performing the actual maintenance function. This measure is expressed by a two-character alphabetical abbreviation (e.g., ea, in, pr). If the unit of measure differs from the unit of issue, requisition the lowest unit of issue that will satisfy the requirements.

(1) ITEM NUMBER	(2) LEVEL	(3) NATIONAL STOCK NUMBER	(4) DESCRIPTION	(5) U/M
1.	F	8040-00-701-9616	Sealant, RTV	1 PT
2.	F	6850-00-274-5421	Solvent, Cleaning PD-680 Type II	5 GL
3.	F	8040-01-033-7507	Adhesive (Sico-met) 7000	1 TU

OPERATOR, ORGANIZATIONAL AND DIRECT SUPPORT, MAINTENANCE REPAIR PARTS AND SPECIAL TOOLS LIST

SECTION I. INTRODUCTION

1. **SCOPE.** This RPSTL lists and authorizes spares and repair parts; special tools; special test, measurement, and diagnostic equipment (TMDE); and other special support equipment required for performance of operator, organizational and direct support of the CCR Nozzle Assembly. It authorizes the requisitioning, issue, and disposition of spares, repair parts and special tools as indicated by the source, maintenance and recoverability (SMR) codes.

2. **GENERAL.** In addition to this section, Introduction, this Repair Parts and Special Tools List is divided into the following sections:

a. **Section II. Repair Parts List.** A list of spares and repair parts authorized by this RPSTL for use in the performance of maintenance. The list also includes parts which must be removed for replacement of the authorized parts. Parts lists are composed of functional groups in ascending alphanumeric sequence, with the parts in each group listed in ascending figure and item number sequence. Bulk materials are listed in item name sequence. Repair parts kits are listed separately in their own functional group within Section II. Repair parts for repairable special tools are also listed in this section. Items listed are shown on the associated illustration(s)/figure(s).

b. **Section III. Special Tools List.** A list of special tools, special TMDE, and other special support equipment authorized by this RPSTL (as indicated by Basis of Issue (BOI) information in DESCRIPTION AND USABLE ON CODE column) for the performance of maintenance.

c. **Section IV. Cross-references Indexes.** A list, in National Item Identification Number (NIIN) sequence, of all National stock numbered items appearing in the listing, followed by a list in alphanumeric sequence of all part numbers appearing in the listings. National stock numbers and part numbers are cross-referenced to each illustration figure and item number appearance. The figure and item number index lists figure and item number in alphanumeric sequence and cross-references NSN, FSCM and part number.

3. **EXPLANATION OF COLUMNS (SECTIONS II AND III).**

a. **ITEM NO. (Column (1)).** Indicates the number used to identify items called out in the illustration.

b. SMR Code (Column (2)). The Source, Maintenance, and Recoverability (SMR) code is a 5-position code containing supply/requisitioning information, maintenance category authorization criteria, and disposition instruction, as shown in the following breakout:

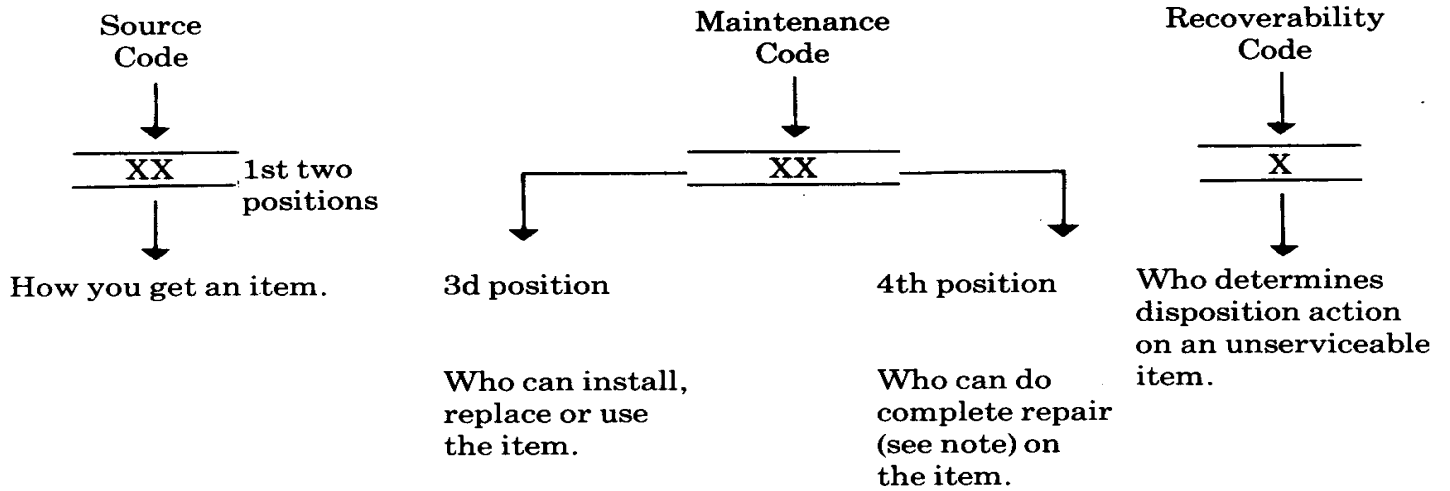

*Complete Repair: Maintenance capacity, capability, and authority to perform all corrective maintenance tasks of the "Repair" function in a use/user environment in order to restore serviceability to a failed item.

(1) Source Code. The source code tells you how to get an item needed for maintenance, repair, or overhaul of an end item/equipment. Explanations of source codes follows:

Code	Explanation
<div style="border: 1px solid black; padding: 5px; width: fit-content;"> PA PB PC** PD PE PF PG </div>	Stocked items; use the applicable NSN to request/requisition items with these source codes. They are authorized to the category indicated by the code entered in the 3d position of the SMR code. **NOTE: Items coded PC are subject to deterioration.
<div style="border: 1px solid black; padding: 5px; width: fit-content;"> KD KF KB </div>	Items with these codes are not to be requested/requisitioned individually. They are part of a kit which is authorized to the maintenance category indicated in the 3d position of the SMR code. The complete kit must be requisitioned and applied.
<div style="border: 1px solid black; padding: 5px; width: fit-content;"> MO—Made at org/ AVUM category MF—Made at DS/ AVUM category MH—Made at GS category ML—Made at Specialized Repair Activity (SRA) MD—Made at Depot </div>	Items with these codes are not to be requested/requisitioned individually. They must be made from bulk material which is identified by the part number in the DESCRIPTION and USABLE ON CODE (UOC) column and listed in the Bulk Material group of

Explanation

- AO —Assembled by org/AVUM category
- AF —Assembled by DS/AVUM category
- AH —Assembled by GS category
- AL —Assembled by SRA
- AD —Assembled by Depot

Items with these codes are not to be requested/requisitioned individually. The parts that make up the assembled item must be requisitioned or fabricated and assembled at the level of maintenance indicated by the source code. If the 3d position code of the SMR code authorizes you to replace the item, but the source code indicates the items are assembled at a higher level, order the item from the higher level of maintenance.

Explanation

- XA--Do not requisition an "XA"-coded item. Order its next higher assembly. (Also, refer to the NOTE below.)
- XB--If an "XB" item is not available from salvage, order it using the FSCM and part number given.
- XC--Installation drawing, diagram, instruction sheet, field service drawing, that is identified by manufacturer's part number.
- XD--Item is not stocked. Order an "XD"-coded item through normal supply channels using the FSCM and part number given, if no NSN is available.

NOTE

Cannibalization or controlled exchange, when authorized, may be used as a source of supply for items with the above source codes, except for those source coded "XA" or those aircraft support items restricted by requirements of AR 750-1.

(2) Maintenance Code. Maintenance codes tells you the level(s) of maintenance authorized to USE and REPAIR support items. The maintenance codes are entered in the third and fourth positions of the SMR code as follows:

- (a) The maintenance code entered in the third position tells you the lowest maintenance level authorized to remove, replace, and use an item. The maintenance code entered in the third position will indicate authorization to one of the following levels of maintenance.

Code	Application/Explanation
C	--Crew or operator maintenance done within organizational or aviation unit maintenance.
0	--Organizational or aviation unit category can remove, replace, and use the item.
F	--Direct support or aviation intermediate level can remove, replace, and use the item.

- H --General support level can remove, replace, and use the item.
- L --Specialized repair activity can remove, replace, and use the item.
- D --Depot level can remove, replace, and use the item.

(b) The maintenance code entered in the fourth position tells whether or not the item is to be repaired and identifies the lowest maintenance level with the capability to do complete repair (i.e., perform all authorized repair functions.) NOTE: Some limited repair may be done on the item at a lower level of maintenance, if authorized by the Maintenance Allocation Chart (MAC) and SMR codes. This position will contain one of the following maintenance codes.

Code	Application/Explanation
0	--Organizational or (aviation unit) is the lowest level that can do complete repair of the item.
F	--Direct support or aviation intermediate is the lowest level that can do complete repair of the item.
H	--General Support is the lowest level that can do complete repair of the item.
L	--Specialized repair activity is the lowest level that can do complete repair of the item.
D	--Depot is the lowest level that can do complete repair of the item.
Z	--Nonreparable. No repair is authorized.
B	--No repair is authorized. (No parts or special tools are authorized for the maintenance of a "B" coded item). However, the item may be reconditioned by adjusting, lubricating, etc., at the user level.

(3) Recoverability Code. Recoverability codes are assigned to items to indicate the disposition action on unserviceable items. The recoverability code is entered in the fifth position of the SMR Code as follows:

Recoverability Codes	Application/Explanation
Z	--Nonreparable item. When unserviceable, condemn and dispose of the item at the level of maintenance shown in 3d position of SMR Code.

Recoverability Codes	Application/Explanation
O	--Reparable item. When uneconomically reparable, condemn and dispose of the item at organizational or aviation unit level.
F	--Reparable item. When uneconomically reparable, condemn and dispose of the item at the direct support or aviation intermediate level.
H	--Reparable item. When uneconomically reparable, condemn and dispose of the item at the general support level.
D	--Reparable item. When beyond lower level repair capability, return to depot. Condemnation and disposal of item not authorized below depot level.
L	--Reparable item. Condemnation and disposal not authorized below specialized repair activity (SRA).
A	--Item requires special handling or condemnation procedures because of specific reasons (e.g., precious metal content, high dollar value, critical material, or hazardous material). Refer to appropriate manuals/directives for specific instructions.

c. FSCM (Column (3)). The Federal Supply Code for Manufacturer (FSCM) is a 5-digit numeric code which is used to identify the manufacturer, distributor, or Government agency, etc., that supplies the item.

d. PART NUMBER (Column (4)). Indicates the primary number used by the manufacturer, (individual, company, firm, corporation, or Government activity), which controls the design and characteristics of the item by means of its engineering drawings, specifications standards, and inspection requirements to identify an item or range of items.

NOTE

When you use an NSN to requisition an item, the item you receive may have a different part number from the part ordered.

e. DESCRIPTION AND USABLE ON CODE (UOC) (Column (5)). This column includes the following information:

- (1) The Federal item name and, when required, a minimum description to identify the item.
- (2) The physical security classification of the item is indicated by the parenthetical entry, e.g., Phy Sec C1 - Confidential, Phy Sec C1 (S) - Secret, Phy Sec C1 (T)- Top Secret.

- (3) Items that are included in kits and sets are listed below the name of the kit or set.
- (4) Spare/repair parts that make up an assembled item are listed immediately following the assembled item line entry.
- (5) Part numbers for bulk materials are referenced in this column in the line item entry for the item to be manufactured/fabricated.
- (6) When the item is not used with all serial numbers of the same model, the effective serial numbers are shown on the last line(s) of the description (before UOC).
- (7) The usable on code, when applicable (see paragraph 5, Special Information).
- (8) In the Special Tools List section, the basis of issue (BOI) appears as the last line(s) in the entry for each special tool, special TMDE, and other special support equipment. When density of equipments supported exceeds density spread indicated in the basis of issue, the total authorization is increased proportionately.
- (9) The statement "END OF FIGURE" appears just below the last item description in Column 5 for a given figure in both Section II and Section III.
- (10) The indenture, shown as dots appearing before the repair part, indicates that the item is a repair part of the next higher assembly.

f. QTY (Column (6)). The QTY (quantity per figure column) indicates the quantity of the item used in the breakout shown on the illustration figure, which is prepared for a functional group, subfunctional group, or an assembly. A "V" appearing in this column in lieu of a quantity indicates that the quantity is variable and may vary from application to application.

4. EXPLANATION OF COLUMNS (SECTION IV).

a. NATIONAL STOCK NUMBER (NSN) INDEX.

(1) **STOCK NUMBER column.** This column lists the NSN by National item identification number

(NIIN) sequence. The NIIN consists of the last nine digits of the
NSN
 NSN, i.e. (5305-01-574-1467).
 NIIN

When using this column to locate an item, ignore the first 4 digits of the NSN. However, the complete NSN should be used when ordering items by stock number.

(2) **FIG. column.** This column lists the number of the figure where the item is identified/located. The figures are in numerical order in Section II and Section III.

(3) **ITEM column.** The item number identifies the item associated with the figure listed in the adjacent FIG. column. This item is also identified by the NSN listed on the same line.

b. **PART NUMBER INDEX.** Part numbers in this index are listed by part number in ascending alphanumeric sequence (i.e., vertical arrangement of letter and number combination which places the first letter or digit of each group in order A through Z, followed by the numbers 0 through 9 and each following letter or digit in like order).

(1) **FSCM column.** The Federal Supply Code for Manufacturer (FSCM) is a 5-digit numeric code used to identify the manufacturer, distributor, or Government agency, etc., that supplies the item.

(2) **PART NUMBER column.** Indicates the primary number used by the manufacturer (individual, firm, corporation, or Government activity), which controls the design and characteristics of the item by means of its engineering drawings, specifications standards, and inspection requirements to identify an item or range of items.

(3) **STOCK NUMBER column.** This column lists the NSN for the associated part number and manufacturer identified in the PART NUMBER and FSCM columns to the left.

(4) **FIG. column.** This column lists the number of the figure where the item is identified/located in Sections II and III.

(5) **ITEM column.** The item number is that number assigned to the item as it appears in the figure referenced in adjacent figure number column.

c. **FIGURE AND ITEM NUMBER INDEX.**

(1) **FIG. column.** This column lists the number of the figure where the item is identified/located in Section II and III.

(2) **ITEM column.** The item number is that number assigned to the item as it appears in the figure referenced in the adjacent figure number column.

(3) **STOCK NUMBER column.** This column lists the NSN for the item.

(4) **FSCM column.** The Federal Supply Code for Manufacturer (FSCM) is a 5-digit numeric code used to identify the manufacturer, distributor, or Government agency, etc., that supplies the item.

(5) **PART NUMBER column.** Indicates the primary number used by the manufacturer (individual, firm, corporation, or Government activity), which controls the design and characteristics of the item by means of its engineering drawings, specifications standards, and inspection requirements to identify an item or range of items.

5. SPECIAL INFORMATION.

a. **USABLE ON CODE.** The usable on code appears in the lower left corner of the Description column heading. Usable on codes are shown as "UOC: " in the Description Column (justified left) on the last line applicable item description/ nomenclature. Uncoded items are applicable to all models. Identification of the usable on codes used in the RPSTL are:

Code	Used On
EAL	AE83206R
EBV	AE83501R

b. **ASSOCIATED PUBLICATIONS.** Not Applicable

6. HOW TO LOCATE REPAIR PARTS.

a. **When National Stock Number or Part Number is NOT Known.**

- (1) **First.** Using the table of contents, determine the assembly group for subassembly group to which the item belongs. This is necessary since figures are prepared for assembly groups and subassembly groups, and listings are divided into the same groups.
- (2) **Second.** Find the figure covering the assembly group or subassembly group to which the item belongs.
- (3) **Third.** Identify the item on the figure and note the item number.
- (4) **Fourth.** Refer to the Repair Parts List for the figure to find the part number for the item number noted on the figure.
- (5) **Fifth.** Refer to the Part Number Index to find the NSN, if assigned.

b. **When National Stock Number or Part Number is Known:**

- (1) **First.** Using the Index of National Stock Numbers and Part Numbers, find the pertinent National Stock Number or Part Number. The NSN index is in National Item Identification Number (NIIN) sequence (see 4a(1)). The part numbers in the Part Number index are listed in ascending alphanumeric sequence (see paragraph 4b). Both indexes cross-reference you to the illustration figure and item number of the item you are looking for.
- (2) **Second.** After finding the figure and item number, verify that the item is the one you are looking for, then locate the item number in the repair parts list for the figure.

7. **ABBREVIATIONS.** Abbreviations used in this manual are listed in MIL-STD-12.

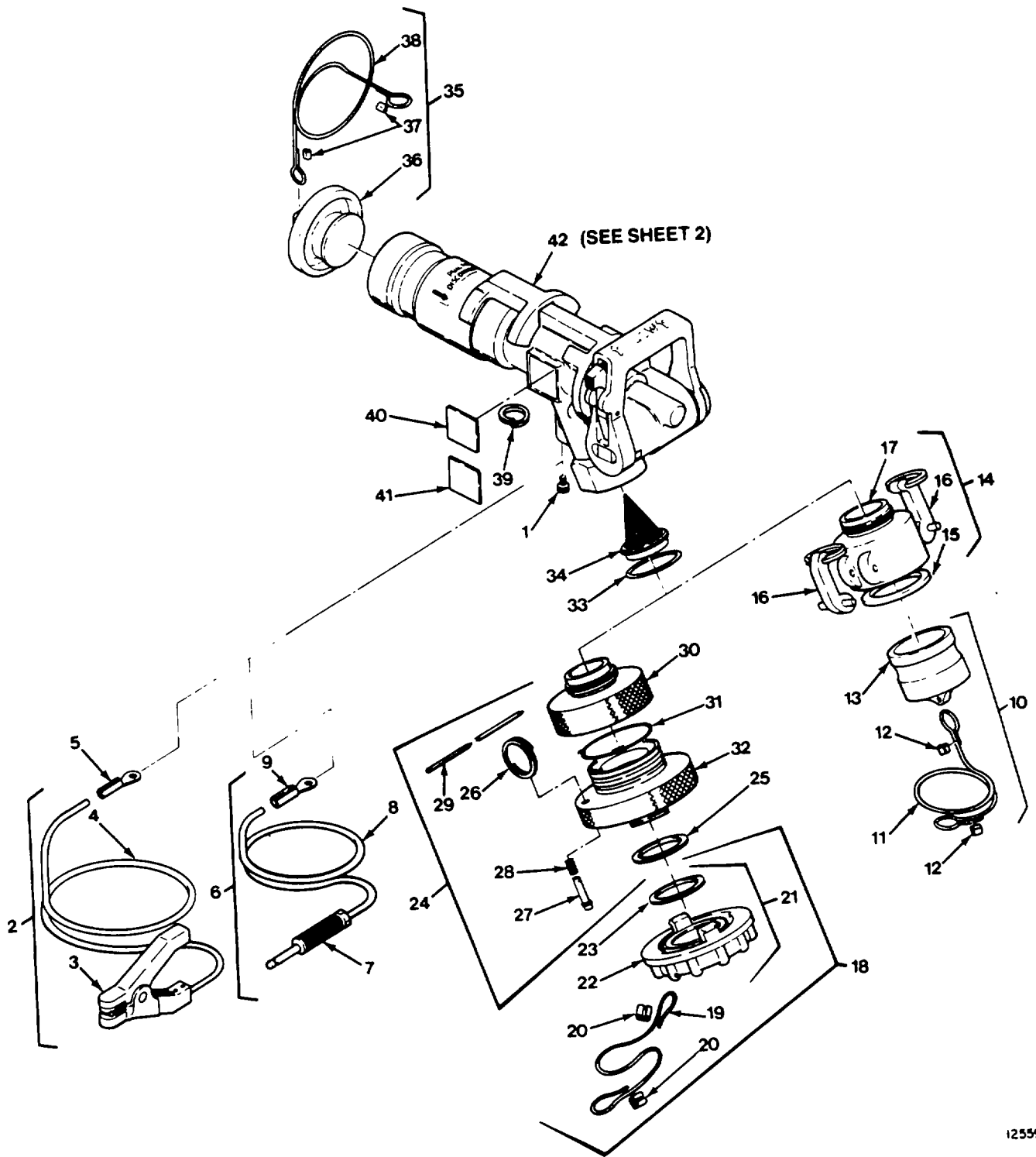

125598

Figure 1. CCR Nozzle Assembly (Sheet 1 of 2)

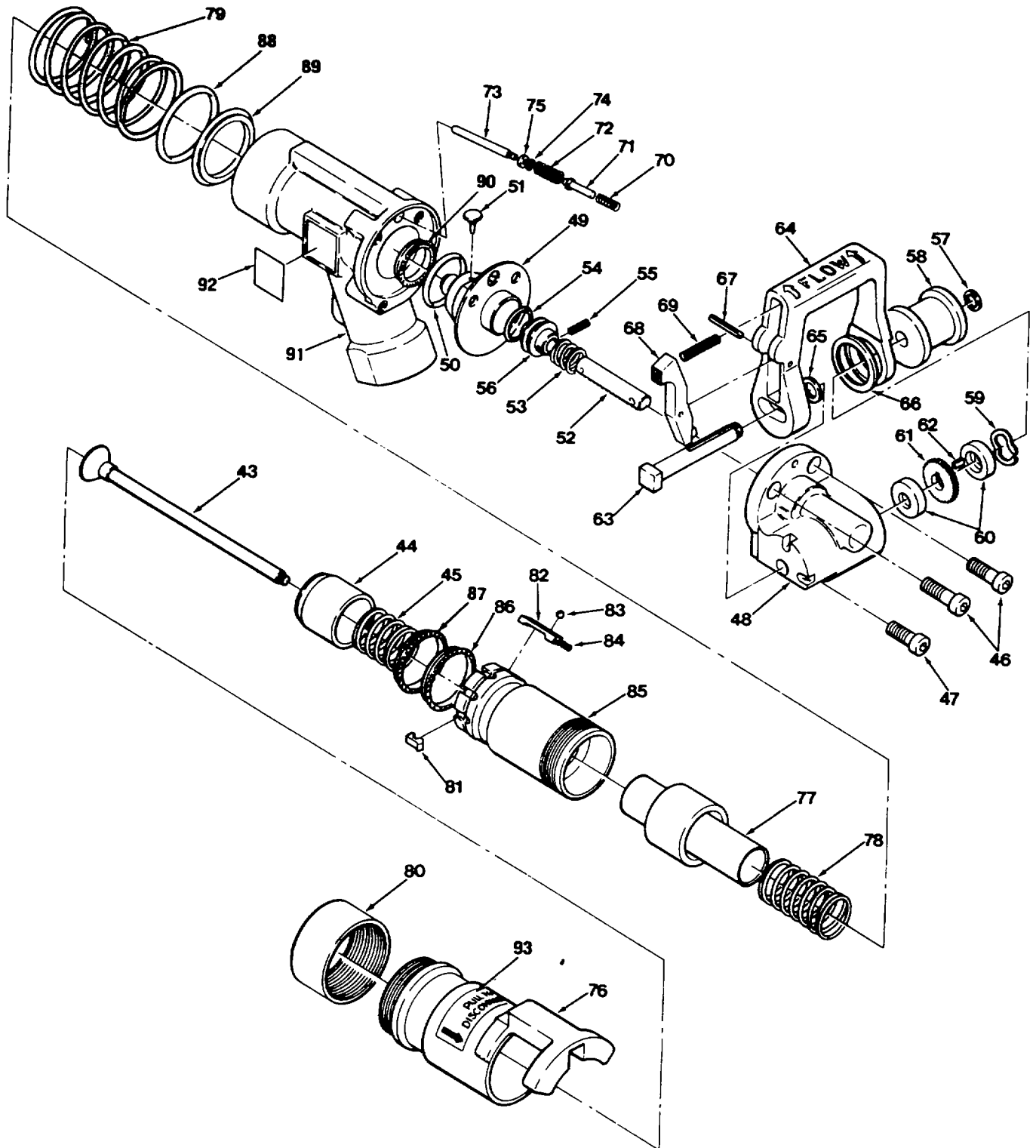

1178C

Figure 1. CCR Nozzle Assembly (Sheet 2 of 2)

Change 3 F-10

SECTION II

TM 5-4930-234-13&P C06

(1) ITEM NO	(2) SMR CODE	(3) CAGEC	(4) PART NUMBER	(5) DESCRIPTION AND USABLE ON CODES (UOC)	(6) QTY
GROUP 01.NOZZLE ASSEMBLY					
FIGURE 1. CCR NOZZLE ASSEMBLY					
1	PAOZZ	96906	MS16995-35	SCREW, CAP, SOCKET HE.....	1
2	AOOZZ	00624	AE24791-009	GROUND CLIP ASSY.....	1
3	PAOZZ	81349	M83413/7-1	.CLIP, ELECTRICAL.....	1
4	MOOZZ	19099	677P18	.CABLE MAKE FROM BULK MATERIAL P/N AE24789-001, (FSCM 00624), 87.00 IN.REQUIRED.....	1
5	XDOZZ	96906	MS35340-57	.WASHER, LOCK.....	1
6	AOOFF	00624	AE24791-006	GROUND PLUG ASSY.....	1
7	PAOZZ	81349	M83413/4-1	.PLUG, TIP.....	1
8	MOOZZ	19099	677P19	.CABLE HAKE FORM BULK MAT, P/N AE24789-001 (FSCM 00624), 44.00 IN.REQUIRED.....	1
9	XDOZZ	96906	MS35340-19	.EYE CABLE.....	1
10	AOOFF	00624	AE83931R	PLUG ASSEMBLY.....	1
11	MOOZZ	19099	677P20	UOC:EAL .ROPE, WIRE MAKE FORM BULK MATERIAL P/N MIL-W-83420 (FSCM 81349), 16.00 IN.REQUIRED.....	1
12	PAOZZ	76691	168-3-VC	UOC:EAL .SWAGING SLEEVE, WIRE.....	2
13	PAOZZ	96906	MS27029-11	UOC:EAL .PLUG, QUICK DISCONNE.....	1
14	XDOFF	00624	AE83932R	UOC:EAL CAM LOCK ASSEMBLY.....	1
15	PAOZZ	96906	MS27030-6	UOC:EAL .GASKET PART OF KIT P/N AE20074-053 PART OF KIT P/N AE20074-052.....	1
16	XDFZZ	81718	H-1833	UOC:EAL .CAM ARM & PIN ASSY.....	2
17	XDFZZ	00624	AE83574R	UOC:EAL .BODY, CAM LOCK.....	1
18	AOOFF	00624	AE83936R	UOC: EAL CAP ASSEMBLY.....	1
19	MOOZZ	19099	677P21	UOC:EBV .ROPE, WIRE MAKE FROM BULK MATERIAL, P/N MIL-W-83420 (FSCM 81349), 12.00 IN.REQUIRED.....	1
19	PAOZZ	81349	M83420/3-001	UOC:EBV .ROPE, WIRE.....	1
20	PAOZZ	76691	168-3-VC	UOC:EBV .SWAGING SLEEVE, WIRE.....	2
21	AOOFF	00624	AE82155R	UOC:EBV .DUST CAP ASSEMBLY.....	1
22	XDOZZ	00624	AE85183R	UOC:EBV ..DUST CAP SUBASSY.....	1
23	PAOZZ	00624	AE18900-076	UOC:EBV ..SEAL.....	1

SECTION II

TM 5-4930-234-13&P C06

(1) ITEM NO	(2) SMR CODE	(3) CAGEC	(4) PART NUMBER	(5) DESCRIPTION AND USABLE ON CODES (UOC)	(6) QTY
24	PAFFF	00624	AE70725R	ADAPTER, PRESSURE FU..... UOC:EBV	1
25	PAOZZ	00624	AE18900-076	.SEAL UOC:EBV	1
26	PAOZZ	00624	AE83144Z	.RING UOC:EBV	1
27	XDFZZ	00624	AE83630Z	.PIN UOC:EBV	1
28	XDFZZ	00624	AE10488-457	.SPRING..... UOC:EBV	1
29	XDFZZ	00624	900803-4-28C	.WIRE UOC:EBV	1
30	XDFZZ	00624	AE83933R	.ADAPTER UOC:EBV	1
31	PAFZZ	00624	22504-230	.PACKING, PERFORMED UOC:EBV	1
32	XDFZZ	00624	AE84592R	.ADAPTER SUB ASSY UOC:EBV	1
33	PAOZZ	96906	MS29513-134	PACKING, PREFORMED PART OF KIT P/N..... AE20074-053	1
34	PAOZZ	00624	AE83576R	STRAINER PART OF KIT P/N AE20074-053.....	1
35	AOOOO	00624	AE83570R	CAP ASSEMBLY.....	1
36	XDOZZ	00624	AE83930R	.CAP	1
37	PAFZZ	76691	168-3-VC	.SWAGING SLEEVE, WIRE	2
38	PAFZZ	18876	9083097	.ROPE,WIRE MAKE FROM BULK MATERIAL, P/N MIL-W-83420 (FSCM 81349), 16.00 IN.REQUIRED.....	1
39	PAOZZ	84256	19-4CD	RING	1
40	XDFZZ	00624	23052-3	LABEL, I.D..... UOC:EAL	1
41	XDFZZ	00624	23052-4	LABEL, I.D..... UOC:EBV	1
42	PBFFF	00624	AE85107R	NOZZLE SUBASSY FUEL.....	1
43	XDFZZ	00624	AE84745R	.PLUNGER.....	1
44	XDFZZ	00624	AE83545R	..SLEEVE, SAFETY PART OF KIT P/N AE20074-053	1
45	XDFZZ	00624	AE10488-445	.SPRING, SAFETY SLV.....	1
46	PAFZZ	96906	MS16995-79	.SCREW, CAP, SOCKET HE.....	2
47	PAFZZ	96906	MS16995-77	.SCREW, CAP, SOCKET HE.....	1
48	XDFZZ	00624	AE83550R	.CAP, END	1
49	XDFZZ	00624	AE83549R	.GUIDE, BONDED PART OF KIT P/N AE20074-053	1
50	PAFZZ	96906	MS29513-129	.PACKING, PREFORMED PART OF KIT P/N..... AE20074-053 PART OF KIT P/N AE20074- 052	1
51	XDFZZ	00624	AE84014H	.VALVE, CHECK PART OF KIT P/N AE20074 -053 PART OF KIT P/N AE20074-052.....	1
52	XDFZZ	00624	AE83541Z	.RACK	1
53	XDFZZ	00624	AE10488-450	.SPRING,PSTN RETURN.....	1
54	PAFZZ	96906	MS29513-214	.PACKING, PREFORMED PART OF KIT P/N AE20074-053 PART OF KIT P/N AE20074- 052	1

SECTION II

TM 5-4930-234-13&P C03

(1) ITEM NO	(2) SMR CODE	(3) FSCM	(4) PART NUMBER	(5) DESCRIPTION AND USABLE ON CODES (UOC)	(6) QTY
55	XDFZZ	96906	MS171530	.PIN, SPRING	1
56	XDFZZ	00624	AE83551R	.PISTON.....	1
57	XDFZZ	80756	RSN50S	.RING, RETAINING PART OF KIT P/N	1
				AE20074-053	
58	XDFZZ	00624	AE83543Z	.PLUG	1
59	XDFZZ	51814	SSR-0087-S17	.WASHER, COMPRESSION	1
60	XDFZZ	00624	AE18033-025	.BUSHING.....	2
61	XDFZZ	00624	AE83572R	.PINION.....	1
62	PBFZZ	00624	AE26329-001	.KEY, MACHINE PART OF KIT P/N AE20074	1
				-053.....	
63	XDFZZ	00624	AE15881-078	.PIN, FLOW CONTROL	1
64	XDFZZ	00624	AE83553R	.HANDLE	1
65	XDFZZ	00624	AE93643E	.WASHER, NON-METALIC PART OF KIT P/N	1
				AE20074-053	
66	XDFZZ	00624	AE18067-036	.WASHER PART OF KIT P/N AE20074-053.....	1
67	PAFZZ	96906	MS16562-225	.PIN, SPRING	1
68	XDFZZ	00624	AE84340R	.LATCH, THUMB	1
69	XDFZZ	00624	AE10488-453	.SPRING, LATCH	1
70	XDFZZ	00624	AE10488-449	.SPRING, IND RETURN	1
71	XDFZZ	00624	AE15881-076	.PIN, INDICATOR	1
72	XDFZZ	00624	AE10488-448	.SPRING, SAFETY	1
73	XDFZZ	00624	AE18034-006	.SHAFT, INDICATOR	1
74	PBFZZ	96906	MS16634-4015	.RING, RETAINING	1
75	XDFZZ	00624	AE18033-023	.BUSHING, INDICATOR.....	1
76	XDFZZ	00624	AE83573R	.SLEEVE, PULLBACK	1
77	XDFZZ	00624	AE83569R	.SLEEVE, PRESS RGLTR.....	1
78	XDFZZ	00624	AE10488-447	.SPRING, PRESS RGLTR PART OF KIT P/N	1
				AE20074-053	
79	XDFZZ	00624	AE10488-446	.SPRING, PULLBACK SLV.....	1
80	XDFZZ	00624	AE83571R	.SLEEVE, NOSE	1
81	XDFZZ	00624	AE84494R	.LATCH	6
82	XDFZZ	00624	AE15881-079	.PIN, RELEASE.....	2
83	PAFZZ	96906	MS19060-4812	.BALL, BEARING	2
84	XDFZZ	00624	AE10488-451	.SPRING, RELEASE PIN.....	2
85	XDFZZ	00624	AE83577R	.ADAPTER	1
86	XDFZZ	00624	AE18900-088	.SEAL, ADAPTER PART OF KIT P/N.....	1
				AE20074-053 PART OF KIT P/N AE20074-052	
87	PAFZZ	00624	AE18900-148	.SEAL, VACUUM RELEASE PART OF KIT P/N	1
				AE20074-053 PART OF KIT P/N AE20074-052.....	
88	XDFZZ	96906	MS29513-228	.PACKING, PREFORMED PART OF KIT P/N	1
				AE20074-053 PART OF KIT P/N AE20074-052	
89	XDFZZ	00624	AE18900-089	.SEAL, PRESS RGLTR PART OF KIT P/N	1
				AE20074-053 PART OF KIT P/N AE20074-052	
90	XDFZZ	00624	AE18900-087	.SEAL, PRESS RGLTR PART OF KIT P/N	1
				AE20074-053 PART OF KIT P/N AE20074-052	
91	XDFZZ	00624	AE83554R-	.BODY	1
92	XDFZZ	00624	23052-5	.LABEL, ID LABEL IDENTIFIES NOZZLE	1

SECTION II

TM 5-4930-234-13&P C03

(1) ITEM NO	(2) SMR CODE	(3) FSCM	(4) PART NUMBER	(5) DESCRIPTION AND USABLE ON CODES (UOC)	(6) QTY
93	XDFZZ	00624	AE13186-009	SUBASSEMBLY, PN AE85107R, ONLY	
	XDFZZ	00624	AE11695-003	.DECAL	1
	XDFZZ	00624	AE13186-012	.PAK, GREASE PART OF KIT P/N AE20074-053 PART OF KIT P/N AE20074-052.....	1
	XDFZZ	00624	AE13186-012	.LABEL, REWORK PART OF KIT P/N AE20074-053 PART OF KIT P/N AE20074-052.....	2
	PAFZZ	00624	AE20074-053	REPAIR KIT, NOZZLE A	1
				GASKET (1) 1-15	
				GASKET (1) 1-15	
				GUIDE, BONDED (1) 1-49	
				KEY, MACHINE (1) 1-62	
				LABEL, REWORK (2) 1-	
				PACKING, PREFORMED (1) 1-33	
				PACKING, PREFORMED (1) 1-50	
				PACKING, PREFORMED (1) 1-54	
				PACKING, PREFORMED (1) 1-88	
				PAK, GREASE (1) 1-	
				RING, RETAINING (1) 1-57	
				SEAL, ADAPTER (1) 1-86	
				SEAL, PRESS RGLTR (1) 1-89	
				SEAL, PRESS RGLTR (1) 1-90	
				SEAL, VACUUM RELEASE (1) 1-87	
				SLEEVE, SAFETY (1) 1-44	
				SPRING, PRESS RGLTR (1) 1-78	
				STRAINER (1) 1-34	
				VALVE, CHECK (1) 1-51	
				WASHER (1) 1-66	
				WASHER, NON-METALIC (1) 1-65	
	PAFZZ	00624	AE20074-052	REPAIR KIT, NOZZLE A	1
				GASKET (1) 1-15	
				GASKET (1) 1-15	
				LABEL, REWORK (2) 1-	
				PACKING, PREFORMED (1) 1-50	
				PACKING, PREFORMED (1) 1-54	
				PACKING, PREFORMED (1) 1-88	
				PAK, GREASE (1) 1-	
				SEAL, ADAPTER (1) 1-86	
				SEAL, PRESS RGLTR (1) 1-89	
				SEAL, PRESS RGLTR (1) 1-90	
				SEAL, VACUUM RELEASE (1) 1-87	
				VALVE, CHECK (1) 1-51	

END OF FIGURE

SECTION II

TM 5-4930-234-13&P C03

(1) ITEM NO	(2) SMR CODE	(3) FSCM	(4) PART NUMBER	(5) DESCRIPTION AND USABLE ON CODES (UOC)	(6) QTY
----------------	-----------------	-------------	--------------------	--	------------

GROUP 02.BULK ITEMS LIST

FIGURE BULK

1	PAOZZ	00624	AE24789-001	.CABLE 100 FT PER ROLL	1
2	PAOZZ	81349	MILW83420	.ROPE, WIRE	1
				UOC:EAL	

END OF FIGURE

F-15/(F-16 Blank)

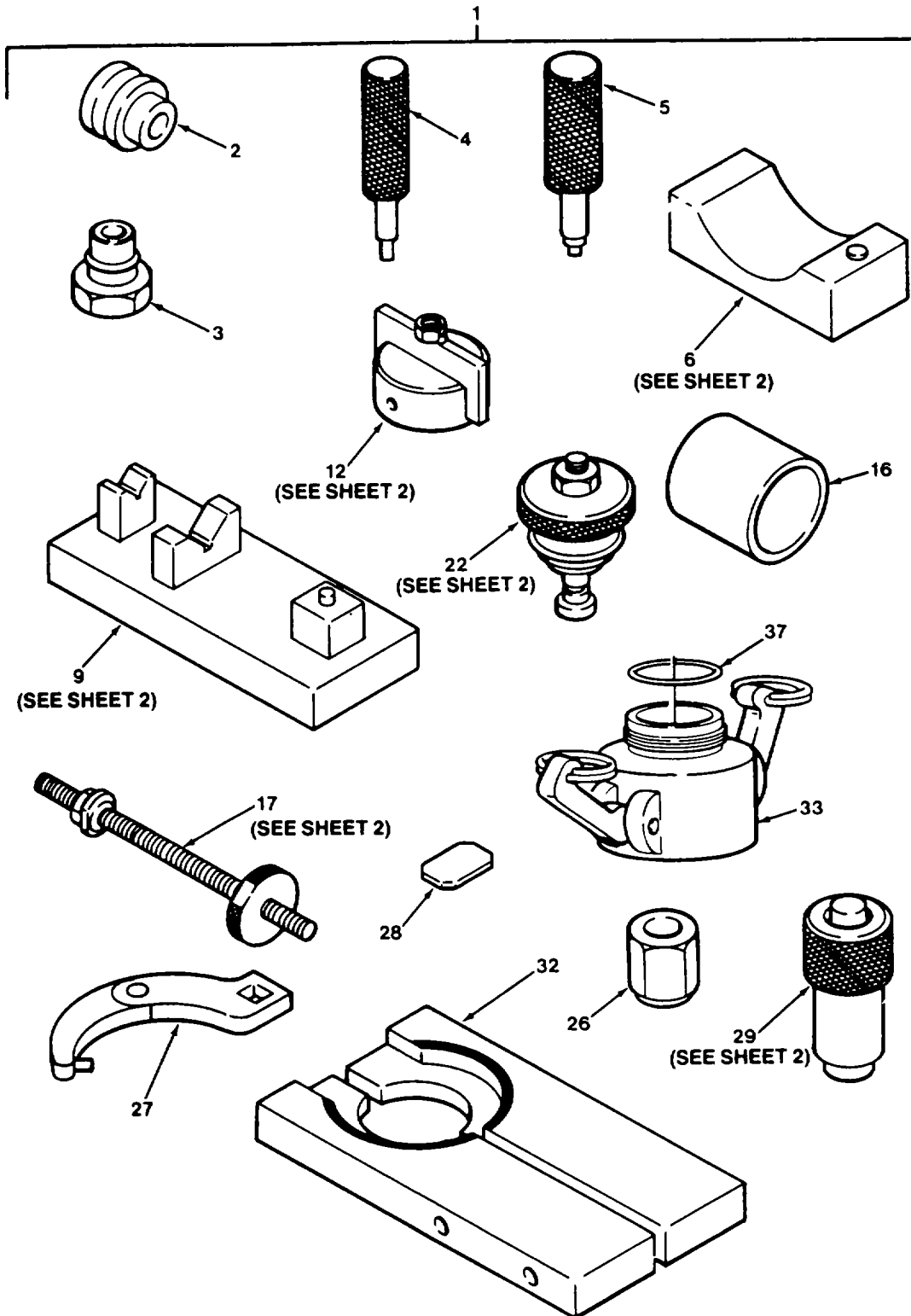

11876A

Figure 2. Special Tools (Sheet 1 of 2)

Change 3 F-17

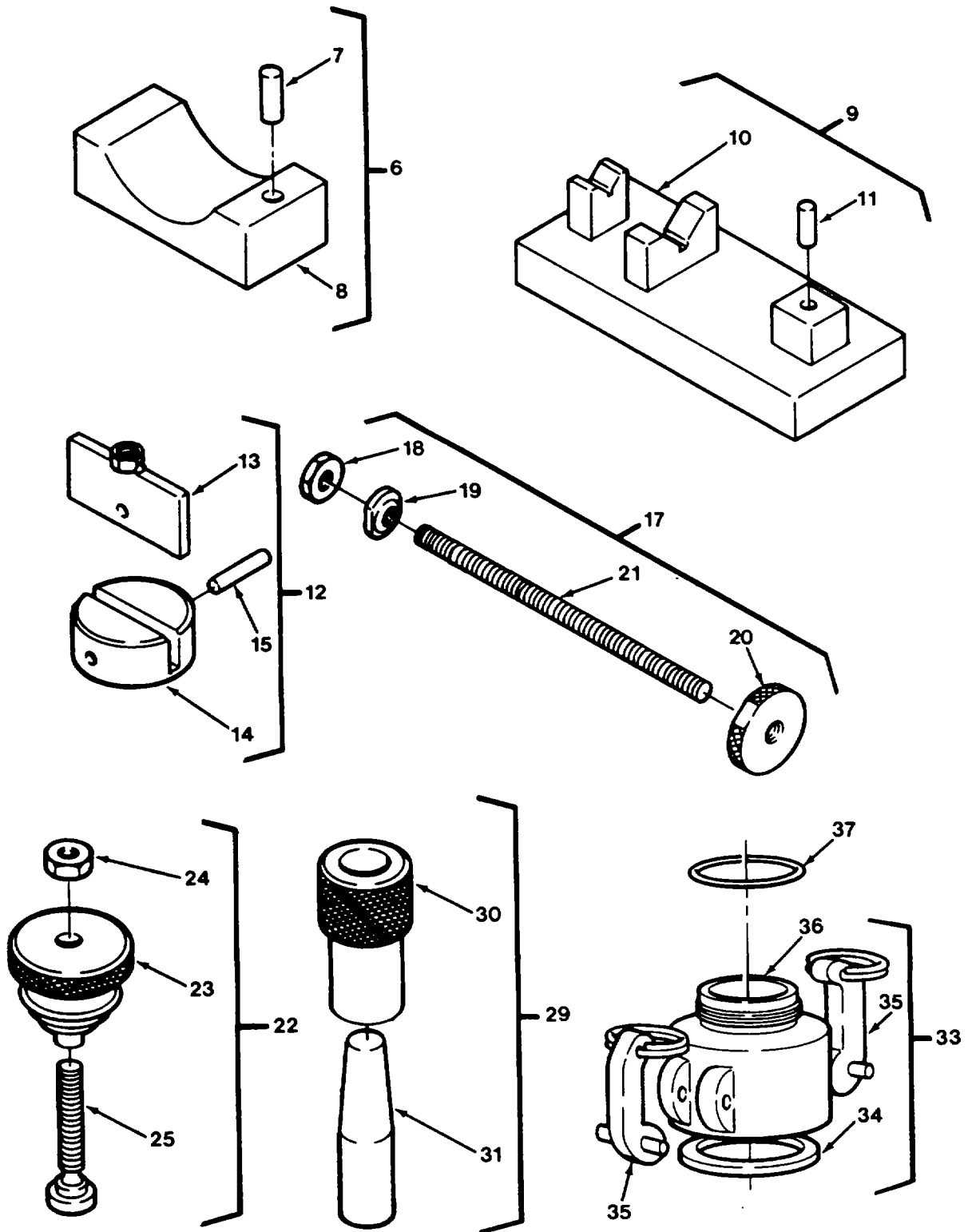

Figure 2. special Tools (Sheet 2 of 2)
Change 3 F-18

SECTION II

TM 5-4930-234-13&P C03

(1) ITEM NO	(2) SMR CODE	(3) FSCM	(4) PART NUMBER	(5) DESCRIPTION AND USABLE ON CODES (UOC)	(6) QTY
----------------	-----------------	-------------	--------------------	--	------------

GROUP 03.SPECIAL TOOLS LIST

FIGURE 2.SPECIAL TOOLS

1	PEFFF	00624	S1391K	KIT, ASSEMBLY TOOL CONTAINS ITEMS1 THROUGH 32.....	
2	XBFZZ	00624	S1391-1	.ADAPTER, TEST, PROOF.....	
3	XBFZZ	00624	S1391-2	.ADAPTER, TEST, PROOF.....	
4	XBFZZ	00624	S1391-3	.TOOL, STAKE, CAMLOCK.....	
5	XBFZZ	00624	S1391-4	.TOOL, STAKE, PIN.....	
6	XBFFF	00624	S1391-5	.PLATE, STAKE, CAMLOCK.....	
7	XBFZZ	00624	SC4568	..PLATE, STAKE.....	
8	XBFZZ	00624	SC4574	..PIN, DOWEL.....	
9	XBFFF	00624	S1391-6	.PLATE, STAKE, PIN.....	
10	XBFZZ	00624	SC4569	..WELDMENT, PL, STAKE.....	
11	XBFZZ	00624	SC4576	..PIN, DOWEL.....	
12	XBFZZ	00624	S1391-7	.TOOL, TORQUE, ADAPTER.....	
13	XBFZZ	00624	SC4566	..PLATE, TORQUE.....	
14	XBFZZ	00624	SC4567	..TOOL, DRIVE, ADAPTER.....	
15	XBFZZ	96906	MS9390-220	..PIN, STRAIGHT, HDLS.....	
16	XBFZZ	00624	S1391-8	.TOOL, MECH, PIN, RLSE.....	
17	XBFFF	00624	S1391-9	.TOOL, POSN, RGLTR.....	
18	XBFZZ	00624	SC4561	..NUT.....	
19	XBFZZ	00624	SC4562	..NUT, LOCATING.....	
20	XBFZZ	00624	SC4563	..NUT, LOCATING.....	
21	XBFZZ	00624	SC4564	..ROD, THREADED.....	
22	XBFZZ	00624	S1391-10	.TOOL, POSN, RACK.....	
23	XBFZZ	00624	SC4565	..ADAPTER, THREADED.....	
24	XBFZZ	96906	MS35650-3392	..NUT, PLAIN, HEXAGON.....	
25	XBFZZ	99862	CL-35-SSC-N	..SCREW, SWIVEL.....	
26	XBFZZ	00624	S1391-11	.TOOL, TORQUE, PLUNGER.....	
27	XBFZZ	00624	S1391-12	.TOOL, TORQUE, SPANNER.....	
28	XBFZZ	00624	S1391-13	.BLOCK, POSN, PIN.....	
29	XBFFF	00624	S1391-14	.TOOL, EXPANSION.....	
30	XBFZZ	00624	SC4570	..PUSHER.....	
31	XBFZZ	00624	SC4571	..CONE.....	
32	XBFZZ	00624	S1391-15	.JAW, VISE.....	
33	XBOFF	00624	AE83932R	.CAM LOCK ASSEMBLY.....	

UOC:EBV

END OF FIGURE

F-19/(F-20 Blank)

SECTION IV

TM 5-4930-234-13&P C06

CROSS- REFERENCE-INDEXES
NATIONAL STOCK NUMBER INDEX

STOCK NUMBER	FIG.	ITEM	STOCK NUMBER	FIG.	ITEM
5305-00-051-8605	1	47			
5999-00-134-5844	1	3			
4010-00-222-4482	1	38			
5330-00-250-0232	1	54			
5330-00-265-1097	1	50			
5935-00-572-5174	1	7			
5330-00-612-2414	1	15			
5330-00-641-0119	1	33			
3110-00-838-5033	1	83			
5315-00-841-4443	1	67			
4730-00-915-5127	1	13			
5305-00-981-3512	1	46			
5305-00-988-7607	1	1			
5365-00-989-0083	1	74			
4010-01-005-4775	1	19			
	BULK	2			
4030-01-088-6263	1	12			
1		20			
1		37			
5330-01-237-3655	1	23			
1		25			
4930-01-237-3656	BULK	1			
4730-01-237-3662	1	34			
5315-01-237-3696	1	62			
5330-01-237-3700	1	31			
4930-01-238-3800	1	42			
5180-01-241-3333	2	1			
4930-01-266-8795	1	26			
1		39			
5330-01-275-7908	1	87			
4930-01-278-6939	1				
4930-01-278-6940	1				
4930-01-350-1721	1	24			

**NATIONAL STOCK NUMBER AND PART NUMBER INDEX
PART NUMBER INDEX**

CAGEC	PART NUMBER	STOCK NUMBER	FIG.	ITEM
00624	AE10488-445		1	45
00624	AE10488-446		1	79
00624	AE10488-447		1	78
00624	AE10488-448		1	72
00624	AE10488-449		1	70
00624	AE10488-450		1	53
00624	AE10488-451		1	84
00624	AE10488-453		1	69
00624	AE10488-457		1	28
00624	AE11695-003		1	
00624	AE13186-009		1	93
00624	AE13186-012		1	
00624	AE15881-076		1	71
00624	AE15881-078		1	63
00624	AE15881-079		1	82
00624	AE18033-023		1	75
00624	AE18033-025		1	60
00624	AE18034-006		1	73
00624	AE18067-036		1	66
00624	AE18900-076	5330-01-237-3655	1	23
			1	25
00624	AE18900-087		1	90
00624	AE18900-088		1	86
00624	AE18900-089		1	89
00624	AE18900-148	5330-01-275-7908	1	87
00624	AE20074-052	4930-01-278-6940	1	
00624	AE20074-053	4930-01-278-6939	1	
00624	AE24789-001	4930-01-237-3656	BULK	1
00624	AE24791-006		1	6
00624	AE24791-009		1	2
00624	AE26329-001	5315-01-237-3696	1	62
1100624	AE70725R	4930-01-350-1721	1	24
00624	AE82155R		1	21
00624	AE83144Z	4930-01-266-8795	1	26
00624	AE83541Z		1	52
00624	AE83543Z		1	58
00624	AE83545R		1	44
00624	AES3549R		1	49
00624	AE83550R		1	48
00624	AE83551R		1	56
00624	AE83553R		1	64
00624	AE83554R		1	91
00624	AE83569R		1	77
00624	AE83570R		1	35
00624	AE83571R		1	80
00624	AE83572R		1	61
00624	AE83573R		1	76
00624	AE83574R		1	17
00624	AE83576R	4730-01-237-3662	1	34
00624	AE83577R		1	85
00624	AE83630Z		1	27

**NATIONAL STOCK NUMBER AND PART NUMBER INDEX
PART NUMBER INDEX**

CAGEC	PART NUMBER	STOCK NUMBER	FIG.	ITEM
00624	AE83930R		1	36
00624	AE83931R		1	10
00624	AE83932R		1	14
			2	33
00624	AE83933R		1	30
00624	AE83936R		1	8
00624	AE84014H		1	51
00624	AE84340R		1	68
00624	AE84494R		1	81
00624	AE84592R		1	32
00624	AE84745R		1	43
00624	AE85107R	4930-01-238-3800	1	42
00624	AE85183R		1	22
00624	AE93643E		1	65
99862	CL-35-SSC-N		2	25
81718	H-1833		1	16
96906	MS16562-225	5315-00-841-4443	1	67
96906	MS16634-4015	5365-00-989-0083	1	74
96906	MS16995-35	5305-00-988-7607	1	1
96906	MS16995-77	5305-00-051-8605	1	7
96906	MS16995-79	5305-00-981-3512	1	46
96906	MS171530		1	55
96906	MS19060-4812	3110-00-838-5033	1	83
96906	MS27029-11	4730-00-915-5127	1	13
96906	MS27030-6	5330-00-612-2414	1	15
96906	MS29513-129	5330-00-265-1097	1	50
96906	MS29513-134	5330-00-641-0119	1	33
96906	MS29513-214	5330-00-250-0232	1	54
96906	MS29513-228		1	88
96906	MS35340-19		1	9
96906	MS35340-57		1	5
96906	MS35650-3392		2	24
96906	MS9390-220		2	15
81349	M83413/4-1	5935-00-572-5174	1	7
81349	M83413/7-1	5999-00-134-5844	1	3
81349	M83420/3-001	4010-01-005-4775	1	19
			BULK	2
80756	RSN50S		1	57
00624	SC4561		2	18
00624	SC4562		2	19
00624	SC4563		2	20
00624	SC4564		2	21
00624	SC4565		2	23
00624	SC4566		2	13
00624	SC4567		2	14
00624	SC4568		2	7
00624	SC4569		2	10
00624	SC4570		2	30
00624	SC4571		2	31
00624	SC4574		2	8
00624	SC4576		2	11

**NATIONAL STOCK NUMBER AND PART NUMBER INDEX
PART NUMBER INDEX**

FSCM	PART NUMBER	STOCK NUMBER	FIG.	ITEM
51814	SSR-0087-S17		1	59
00624	S1391-1		2	2
00624	S1391-10		2	22
00624	S1391-11		2	26
00624	S1391-12		2	27
00624	S1391-13		2	28
00624	51391-14		2	29
00624	S1391-15		2	32
00624	S1391-2		2	3
00624	S1391-3		2	4
00624	S1391-4		2	5
00624	S1391-5		2	6
00624	51391-6		2	9
00624	S1391-7		2	12
00624	S1391-8		2	16
00624	S1391-9		2	17
00624	S1391K	5180-01-241-3333	2	1
76691	168-3-VC	4030-01-088-6263	1	12
			1	20
			1	37
84256	19-4CD	4930-01-266-8795	1	39
00624	22504-230	5330-01-237-3700	1	31
00624	23052-3		1	40
00624	23052-4		1	41
00624	23052-5		1	92
19099	677P18		1	4
19099	677P19		1	8
19099	677P20		1	11
19099	677P21		1	19
19099	677P22		1	38
00624	900803-4-28C		1	29

CROSS REFERENCE INDEXES

FIG.	ITEM	FIGURE AND ITEM NUMBER INDEX STOCK NUMBER	CAGEC	PART NUMBER
BULK	1	4930-01-237-3656	00624	AE24789-001
BULK	2	4010-01-005-4775	81349	MILW83420
1			00624	AE11695-003
1			00624	AE13186-012
1		4930-01-278-6939	00624	AE20074-053
1		4930-01-278-6940	00624	AE20074-052
1	1	5305-00-988-7607	96906	MS16995-35
1	2		00624	AE24791-009
1	3	5999-00-134-5844	81349	M83413/7-1
1	4		19099	677P18
1	5		96906	MS35340-57
1	6		00624	AE24791-006
1	7	5935-00-572-5174	81349	M8341C3/4-1
1	8		19099	677P19
1	9		96906	MS35340-19
1	10		00624	AE83931 R
1	11		19099	677P20
1	12	4030-01-088-6263	76691	168-3-VC
1	13	4730-00-915-5127	96906	MS27029-11
1	14		00624	AE83932R
1	15	5330-00-612-2414	96906	MS27030-6
1	16		81718	H-1833
1	17		00624	AE83574R
1	18		00624	AE83936R
1	19		19099	677P21
1	19	4010-01-005-4775	81349	M83420/3-001
1	20	4030-01-088-6283	76691	168-3-VC
1	21		00624	AE82155R
1	22		00624	AE85183R
1	23	5330-01-237-3655	00624	AE18900-076
1	24	4930-01-350-1721	00624	AE70725R
1	25	5330-01-237-3655	00624	AE18900-076
1	26	4930-01-266-8795	00624	AE83144Z
1	27		00624	AE83630Z
1	28		00624	AE10488-457
1	29		00624	900803-4-28C
1	30		00624	AE83933R
1	31	5330-01-237-3700	00624	22504-230
1	32		00624	AE84592R
1	33	5330-00-641-0119	96906	MS29513-134
1	34	4730-01-237-3662	00624	AE83576R
1	35		00624	AE8357OR
1	36		00624	AE83930R
1	37	4030-01-088-6263	76691	168-3-VC
1	38	4010-00-222-4482	18876	9083097
1	39	4930-01-266-8795	84256	19-4CD
1	40		00624	23052-3
1	41		00624	23052-4
1	42	4930-01-238-3800	00624	AE85107R
1	43		00624	AE84745R
1	44		00624	AE83545R

**CROSS-REFERENCE INDEXES
FIGURE AND ITEM NUMBER INDEX**

FIG.	ITEM	STOCK NUMBER	FSCM	PART NUMBER
1	45		00624	AE10488-445
1	46	5305-00-981-3512	96906	MS16995-79
1	47	5305-00-051-8605	96906	MS16995-77
1	48		00624	AE83550R
1	49		00624	AE83549R
1	50	5330-00-265-1097	96906	MS29513-129
1	51		00624	AE84014H
1	52		00624	AE83541Z
1	53		00624	AE10488-450
1	54	5330-00-250-0232	96906	MS29513-214
1	55		96906	MS171530
1	56		00624	AE83551R
1	57		80756	RSN50S
1	58		00624	AE83543Z
1	59		51814	SSR-0087-S17
1	60		00624	AE18033-025
1	61		00624	AE83572R
1	62	5315-01-237-3696	00624	AE26329-001
1	63		00624	AE15881-078
1	64		00624	AE83553R
1	65		00624	AE93643E
1	66		00624	AE18067-036
1	67	5315-00-841-4443	96906	MS16562-225
1	68		00624	AE84340R
1	69		00624	AE10488-453
1	70		00624	AE10488-449
1	71		00624	AE15881-076
1	72		00624	AE10488-448
1	73		00624	AE18034-006
1	74	5365-00-989-0083	96906	MS16634-4015
1	75		00624	AE18033-023
1	76		00624	AE83573R
1	77		00624	AE83569R
1	78		00624	AE10488-447
1	79		00624	AE10488-446
1	80		00624	AE83571R
1	81		00624	AE84494R
1	82		00624	AE15881-079
1	83	3110-00-838-5033	96906	MS19060-4812
1	84		00624	AE10488-451
1	85		00624	AE83577R
1	86		00624	AE18900-088
1	87	4930-01-275-7908	00624	AE18900-148
1	88	5330-00-291-7337	96906	MS29513-228
1	89		00624	AE18900-089
1	90		00624	AE18900-087
1	91		00624	AE83554R
1	92		00624	23052-5
1	93		00624	AE13186-009
2	1	5180-01-741-3333	00624	S1391K
2	2		00624	S1391-1

CROSS-REFERENCE INDEXES
FIGURE AND ITEM NUMBER INDEX

FIG.	ITEM	STOCK NUMBER	FSCM	PART NUMBER
2	3		00624	S1391-2
2	4		00624	S1391-3
2	5		00624	S1391-4
2	6		00624	S1391-5
2	7		00624	SC4568
2	8		00624	S04574
2	9		00624	S1391-6
2	10		00624	SC4569
2	11		00624	SC4576
2	12		00624	S1391-7
2	13		00624	SC4566
2	14		00624	SC4567
2	15		96906	MS9390-220
2	16		00624	S1391-8
2	17		00624	S1391-9
2	18		00624	S C4561
2	19		00624	SC4562
2	20		00624	SC4563
2	21		00624	SC4564
2	22		00624	S1391-10
2	23		00624	SC4565
2	24		96906	MS35650-3392
2	25		99862	CL-35-SSC-N
2	26		00624	S1391-11
2	27		00624	S1391-12
2	28		00624	S1391-13
2	29		00624	S1391-14
2	30		00624	SC4570
2	31		00624	SC4571
2	32		00624	S1391-15
2	33		00624	AE83932R

These are the instructions for sending an electronic 2028

The following format must be used if submitting an electronic 2028. The subject line must be exactly the same and all fields must be included; however only the following fields are mandatory: 1, 3, 4, 5, 6, 7, 8, 9,10,13, 15,16,17, and 27.

From: "Whomever" <whomever@avma27.army.mil>
To: mpmt%avma28@ft-louis-emh7.army.mil

Subject: DA Form 2028

1. **From:** Joe Smith
2. *Unit:* home
3. **Address:** 4300 Park
4. **City:** Hometown
5. **St:** MO
6. **Zip:** 77777
7. **Date Sent:** 19-OCT-93
8. **Pub no:** 55-2840-229-23
9. **Pub Title:** TM
10. **Publication Date:** 04-JUL-85
11. *Change Number:* 7
12. *Submitter Rank:* MSG
13. **Submitter FName:** Joe
14. *Submitter MName:* T
15. **Submitter LName:** Smith
16. **Submitter Phone:** 123-123-1234
17. **Problem: 1**
18. *Page:* 2
19. *Paragraph:* 3
20. *Line:* 4
21. *NSN:* 5
22. *Reference:* 6
23. *Figure:* 7
24. *Table:* 8
25. *item:* 9
26. *Total.* 123
27. **Text:**

This is the text for the problem below line 27.

INDEX

		Page
	A	
Additional Authorization List		D-1
Administrative Storage	4-13	
	C	
Cam-Lock Coupling Assembly (Organizational)		4-10
Installation	4-10	
Removal	4-10	
Cam-Lock Coupling Assembly (Direct Support)		5-5
Disassembly	5-5	
Inspection	5-5	
Installation	5-7	
Reassembly	5-6	
Removal	5-5	
Replacement	5-5	
Cam-lock Coupling Gasket		3-2
Inspection	3-2	
Reassembly	3-2	
Removal	3-2	
Replacement	3-2	
CCR Nozzle Sub-Assembly		5-10
Cleaning	5-16	
Disassembly	5-10	
Inspection	5-17	
Reassembly	5-19	
Replacement	5-18	
Testing	5-28	
Components of End Item/Basic Issue Items		C-1
Connection of Nozzle, Model AE83206R		2-3
Connection of Nozzle, Model AE83501R		2-6
	D	
Destruction of Army Materiel To Prevent Enemy Use		1-1
Differences Between Models 1-3		
Direct Support Maintenance Instructions		5-1
Disconnection of Nozzle, Model AE83206R		2-6
Disconnection of Nozzle, Model AE83501R		2-9
Dust Cap Assembly	4-4	
Disassembly	4-5	
Inspection	4-5	
Installation	4-5	

INDEX (Continued)

	Page	
Dust Cap Assembly (Continued)		
Reassembly	4-5	
Removal	4-4	
Replacement	4-5	
Dust Plug Assembly	4-5	
Disassembly	4-5	
Inspection	4-5	
Installation	4-7	
Reassembly	4-6	
Removal	4-5	
Replacement	4-6	
E		
Equipment Characteristics, Capabilities, and Features		1-1
Equipment Description and Data		1-2
Expendable/Durable Supplies and Materials List		E-1
Explanation of Columns in the MAC		B-2
G		
General Information	1-1	
Ground Clip Assembly	4-9	
Disassembly	4-9	
Inspection	4-10	
Installation	4-10	
Reassembly	4-10	
Removal	4-9	
Replacement	4-10	
Ground Plug Assembly	4-7	
Disassembly	4-7	
Inspection	4-7	
Installation	4-8	
Reassembly	4-7	
Removal	4-7	
Replacement	4-7	
I		
Inspection	4-1	

INDEX (Continued)

Page		
	L	
Lubrication Instructions	3-1	
	M	
Maintenance Allocation Chart		B-1
Maintenance Forms, Records, and Reports		1-1
Maintenance Functions	B-1	
Maintenance Procedures (Operator)		3-2
Maintenance Procedures (Organizational)		4-4
Maintenance Procedures (Direct Support)		5-5
Miscellaneous Publications		A-1
	N	
Nomenclature Cross Reference List		1-3
	O	
Operating Controls	2-1	
Operating Instructions	2-1	
Operation of Nozzle, Model AE83206R		2-5
Operation of Nozzle, Model AE83501R		2-6
Operation Under Usual Conditions		2-3
Operation Under Unusual Conditions		2-9
Operator Maintenance Instructions		3-1
Operator Preventive Maintenance Checks and Services		2-2
Organizational Maintenance Instructions		4-1
	P	
Packaging	4-14	
Preparation For Storage or Shipment		1-1,
Preventive Maintenance Checks and Services (Operator)		2-2
Principles of Operation	1-3	

INDEX (Continued)

Page

R

References	A-1	
Reporting Equipment Improvement Recommendations (EIR's)		1-1
Repair Parts and Special Tools List		F-1
Repair Parts, Special Tools; Test Equipment, Measurement and Diagnostic Equipment (TMDE); and Support Equipment		4-1

S

Safety, Care, and Handling		1-3
Service Upon Receipt	4-1	
Strainer and O-Ring	3-4	
Inspection	3-5	
Reassembly	3-5	
Removal	3-4	
Replacement	3-5	

T

Technical Manuals	A-1	
Troubleshooting Procedures (Operator)		3-1
Troubleshooting Procedures (Organizational)		4-1
Troubleshooting Procedures (Direct Support)		5-1

U

Unisex Coupling Assembly (Organizational)		4-13
Installation	4-13	
Removal	4-13	
Unisex Coupling Assembly (Direct Support)		5-8
Disassembly	5-9	
Inspection	5-9	
Installation	5-10	
Reassembly	5-10	
Removal	5-8	
Replacement	5-10	
Unisex Coupling Seals	3-3	
Inspection	3-3	
Reassembly	3-4	
Removal	3-3	
Replacement	3-3	

INDEX (Continued)

	Page
Unisex Dust Cap	4-11
Disassembly	4-12
Inspection	4-12
Installation	4-13
Reassembly	4-13
Removal	4-11
Replacement	4-13
Unpacking	4-1
	W
Warranty Information	1-1

By Order of the Secretary of the Army:

Official:

R. L. DILWORTH
Brigadier General, United States Army
The Adjutant General

JOHN A. WICKHAM, JR.
General, United States Army
Chief of Staff

DISTRIBUTION:

To be distributed in accordance with DA For, Organizational Direct Support and General Support Maintenance requirements for Nozzle Assembly, Closed Circuit Refueling (CCN-101/14) (TM 5-4930-226-12&P)

*U.S. GOVERNMENT PRINTING OFFICE 1996 - 406-421 (61133)

The Metric System and Equivalents

Linear Measure

1 centimeter = 10 millimeters = .39 inch
 1 decimeter = 10 centimeters = 3.94 inches
 1 meter = 10 decimeters = 39.37 inches
 1 dekameter = 10 meters = 32.8 feet
 1 hectometer = 10 dekameters = 328.08 feet
 1 kilometer = 10 hectometers = 3,280.8 feet

Weights

1 centigram = 10 milligrams = .15 grain
 1 decigram = 10 centigrams = 1.54 grains
 1 gram = 10 decigrams = .035 ounce
 1 dekagram = 10 grams = .35 ounce
 1 hectogram = 10 dekagrams = 3.52 ounces
 1 kilogram = 10 hectograms = 2.2 pounds
 1 quintal = 100 kilograms = 220.46 pounds
 1 metric ton = 10 quintals = 1.1 short tons

Liquid Measure

1 centiliter = 10 milliliters = .34 fl. ounce
 1 deciliter = 10 centiliters = 3.38 fl. ounces
 1 liter = 10 deciliters = 33.81 fl. ounces
 1 dekaliter = 10 liters = 2.64 gallons
 1 hectoliter = 10 dekaliters = 26.42 gallons
 1 kiloliter = 10 hectoliters = 264.18 gallons

Square Measure

1 sq. centimeter = 100 sq. millimeters = .155 sq. inch
 1 sq. decimeter = 100 sq. centimeters = 15.5 sq. inches
 1 sq. meter (centare) = 100 sq. decimeters = 10.76 sq. feet
 1 sq. dekameter (are) = 100 sq. meters = 1,076.4 sq. feet
 1 sq. hectometer (hectare) = 100 sq. dekameters = 2.47 acres
 1 sq. kilometer = 100 sq. hectometers = .386 sq. mile

Cubic Measure

1 cu. centimeter = 1000 cu. millimeters = .06 cu. inch
 1 cu. decimeter = 1000 cu. centimeters = 61.02 cu. inches
 1 cu. meter = 1000 cu. decimeters = 35.31 cu. feet

Approximate Conversion Factors

<i>To change</i>	<i>To</i>	<i>Multiply by</i>	<i>To change</i>	<i>To</i>	<i>Multiply by</i>
inches	centimeters	2.540	ounce-inches	newton-meters	.007062
feet	meters	.305	centimeters	inches	.394
yards	meters	.914	meters	feet	3.280
miles	kilometers	1.609	meters	yards	1.094
square inches	square centimeters	6.451	kilometers	miles	.621
square feet	square meters	.093	square centimeters	square inches	.155
square yards	square meters	.836	square meters	square feet	10.764
square miles	square kilometers	2.590	square meters	square yards	1.196
acres	square hectometers	.405	square kilometers	square miles	.386
cubic feet	cubic meters	.028	square hectometers	acres	2.471
cubic yards	cubic meters	.765	cubic meters	cubic feet	35.315
fluid ounces	milliliters	29.573	cubic meters	cubic yards	1.308
pints	liters	.473	milliliters	fluid ounces	.034
quarts	liters	.946	liters	pints	2.113
gallons	liters	3.785	liters	quarts	1.057
ounces	grams	28.349	liters	gallons	.264
pounds	kilograms	.454	grams	ounces	.035
short tons	metric tons	.907	kilograms	pounds	2.205
pound-feet	newton-meters	1.356	metric tons	short tons	1.102
pound-inches	newton-meters	.11296			

Temperature (Exact)

°F	Fahrenheit temperature	5/9 (after subtracting 32)	Celsius temperature	°C
----	---------------------------	-------------------------------	------------------------	----

RECOMMENDED CHANGES TO EQUIPMENT TECHNICAL PUBLICATIONS



THEN... JOT DOWN THE DOPE ABOUT IT ON THIS FORM, CAREFULLY TEAR IT OUT, FOLD IT AND DROP IT IN THE MAIL!

SOMETHING WRONG WITH THIS PUBLICATION?

FROM: (PRINT YOUR UNIT'S COMPLETE ADDRESS)

DATE SENT

PUBLICATION NUMBER

PUBLICATION DATE

PUBLICATION TITLE

BE EXACT... PIN-POINT WHERE IT IS

PAGE NO.	PARA-GRAPH	FIGURE NO.	TABLE NO.
----------	------------	------------	-----------

IN THIS SPACE TELL WHAT IS WRONG AND WHAT SHOULD BE DONE ABOUT IT:

TEAR ALONG PERFORATED LINE

PRINTED NAME, GRADE OR TITLE, AND TELEPHONE NUMBER

SIGN HERE:

DA FORM 2028-2 JUL 79

PREVIOUS EDITIONS ARE OBSOLETE.

P.S.—IF YOUR OUTFIT WANTS TO KNOW ABOUT YOUR RECOMMENDATION MAKE A CARBON COPY OF THIS AND GIVE IT TO YOUR HEADQUARTERS.

